



**Sure Flow  
Equipment Inc.**

## DUPLEX STRAINERS

[www.sureflowequipment.com](http://www.sureflowequipment.com)



2011



# CONTENTS COMMITMENT TO QUALITY

## Table of Contents

Contents .....	1
Commitment to Quality .....	1
Duplex Strainers - 3/4" to 4" .....	2
Product Information .....	2
Selection Table and Ordering Information .....	2
Dimensional Data .....	3
Duplex Strainers - 5" to 8" .....	4
Product Information .....	4
Selection Table and Ordering Information .....	4
Options and Dimensional Data .....	5
Pressure Drop Charts .....	6
Warranty .....	Back Cover

## Service Applications



Sewage Treatment Industry

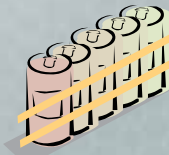

Food Processing Facilities

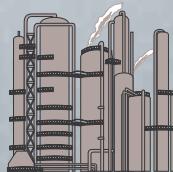

Chemical Plants

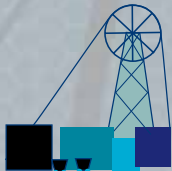

Mining Operations

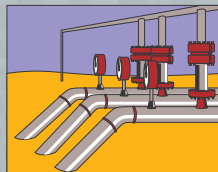

Petrochemical



Cement Manufacturing

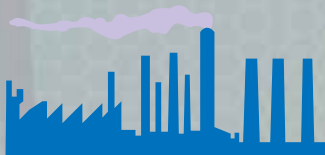

Steel Mills

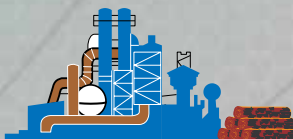

Pulp and Paper

## Commitment to Quality

Sure Flow Equipment Inc. features complete custom engineered design and fabrication expertise within a quality focused state-of-the-art manufacturing facility. Commitment to quality, customer satisfaction and continual improvement is integral to our manufacturing processes and ensures custom engineered strainers meet your design specifications and stringent quality requirements. We've made it easy for you to place your order with confidence.

Sure Flow Equipment Inc. provides industry with Custom Engineered Fabricated Strainers to many design codes. Custom products are designed and manufactured to ASME SECTION VIII, DIV 1, Current Edition. ASME "U" Code Stamp and ASME "UM" Code Stamp are available on certain products as specified in this brochure.

The Sure Flow Equipment Inc. list of Certifications includes:

ISO 9001:2008 Certificate of Registration

ASME "U" Code Stamp Certificate of Authorization and ASME "UM" Code Stamp Certificate of Authorization (ASME Boiler and Pressure Vessel Code; ASME Section VIII, Div 1, Current Edition);

National Board Certified and authorized to apply the "NB" Mark for pressure vessels and/or pressure retaining items manufactured in accordance with ASME "U" Code Stamp and ASME "UM" Code Stamp;

TSSA (Technical Standards & Safety Authority) Certificate of Authorization for the manufacture of pressure vessels in accordance with ASME Boilers and Pressure Vessel Code, Section VIII, Division 1 and CSA Standard B51, Boiler, Pressure Vessel and Pressure Piping Code.

TSSA (Technical Standards & Safety Authority) Certificate of Authorization for the repair and alteration of boilers, pressure vessels, piping, and Category A, B, E & H fittings in accordance with CSA Standard B51, Boiler, Pressure Vessel and Pressure Piping Code.

CE Mark is available

C-TPAT Certified (Customs-Trade Partnership Against Terrorism)

Recognized by PIP (Partners In Protection) for our C-TPAT status

Member of FCI (Fluid Controls Institute) and Vice Chairman of Pipeline Strainer Section



**Sure flow**  
Equipment Inc.

Toll Free: 1-800-263-8251 Toll Free Fax: 1-800-876-1164  
International: 1-905-335-1350 International Fax: 1-905-332-4993  
Email: info@sureflowequipment.com www.sureflowequipment.com



# DUPLEX STRAINERS

Cast Iron, Cast Steel, Cast 316 Stainless Steel, Cast Bronze  
Threaded (T) and Flanged (F) • Sizes 3/4" to 4"

Type **D125CIT & D125CIF** Cast Iron; **D150TCS & D150FCS** Cast Steel;  
**D150TSS & D150FSS** Cast 316 Stainless Steel; **D150TBZ & D150FBZ** Cast Bronze



*A minimum of parts, easily replaced, makes service a snap. Exploded view shows simplicity of design.*

The Sure Flow Duplex Strainer removes dirt and debris from pipelines and protects sensitive system components. The duplex features a design that makes strainer basket servicing a no-hassle operation. The duplex keeps the chamber from overflowing during service. This gives you time to clean or replace the strainer basket without ever having to worry about leakage and overflow. And ... without overflow, there's no need to clean up after servicing the strainer basket.

A unique flow diverter valve cartridge design isolates the two strainer basket chambers and prevents fluid bypass. An easy-to-turn handle operates the cartridge and diverts the system flow from one chamber to the other — the flow in the pipeline is never shut off.

When a strainer basket needs to be cleaned, the lever handle is turned to take it out of service and to divert the flow through the other chamber. The position of the handle clearly indicates at all times which chamber is in service.

No special tools are needed to access the strainer basket for cleaning. The chamber is first drained and then the cover is lifted and swung clear of the chamber opening. The dynamic diverter cartridge seals prevent fluid bypass into the out-of-service chamber — making for easy, hassle-free strainer basket servicing.

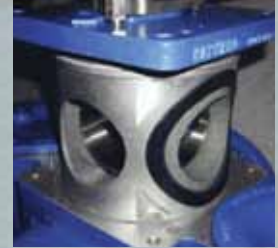

*Should the diverter valve require service, it slides right out the top of the strainer body.*



*Standard body vent on top of strainer makes venting quick and easy.*

Sure Flow Duplex Strainer Selection Table (Sizes 3/4" to 4")

Body and Cartridge Material	Connections	Sizes		Rating	Seat/Seals	Diverter Balls
		Inches	Prefix			
Cast Iron (CI)	Threaded (T)	3/4, 1, 1 1/4, 1 1/2, 2, 2 1/2	0075, 0100, 0125, 0150, 0200, 0250	ASME CL.125 200 psig @ 150 °F	Teflon/ Buna N*	Stainless Steel
	Flanged (F)	1, 1 1/4, 1 1/2, 2, 2 1/2, 3, 4	0100, 0125, 0150, 0200, 0250, 0300, 0400			
Bronze (BZ) Carbon Steel (CS) Stainless Steel (SS)	Threaded (T)	3/4, 1, 1 1/4, 1 1/2, 2, 2 1/2	0075, 0100, 0125, 0150, 0200, 0250	ASME CL.150 200 psig @ 150 °F	Teflon/ Buna N*	Stainless Steel
	Flanged (F)	1, 1 1/4, 1 1/2, 2, 2 1/2, 3, 4	0100, 0125, 0150, 0200, 0250, 0300, 0400			

\* Viton® standard for stainless steel.

## Ordering Information

Example : Include full description

Size	Model	Screen
(Prefix)	Number	Opening
<b>0400</b>	<b>D125CIF</b>	<b>156</b>

4" Flanged Duplex Strainer, Cast Iron,  
Class 125 ASME Flanges, 5/32" Perf Screen

## Notes:

Manufacturer reserves the right to modify dimensions, materials, or design. Please contact Sure Flow Equipment Inc. for certifications.



**Sure flow**  
Equipment Inc.

Toll Free: 1-800-263-8251 Toll Free Fax: 1-800-876-1164  
International: 1-905-335-1350 International Fax: 1-905-332-4993  
Email: info@sureflowequipment.com www.sureflowequipment.com



# DUPLEX STRAINERS

Top View: Threaded Model

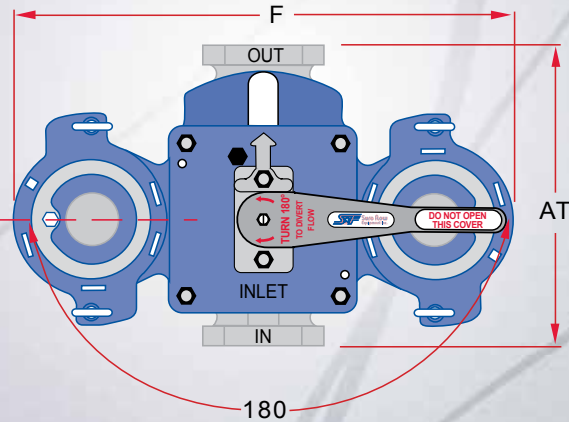

Top View: Flanged Model

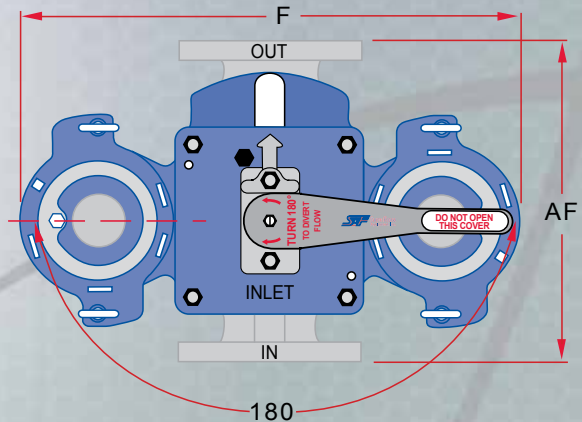

Front View: Flanged and Threaded Models

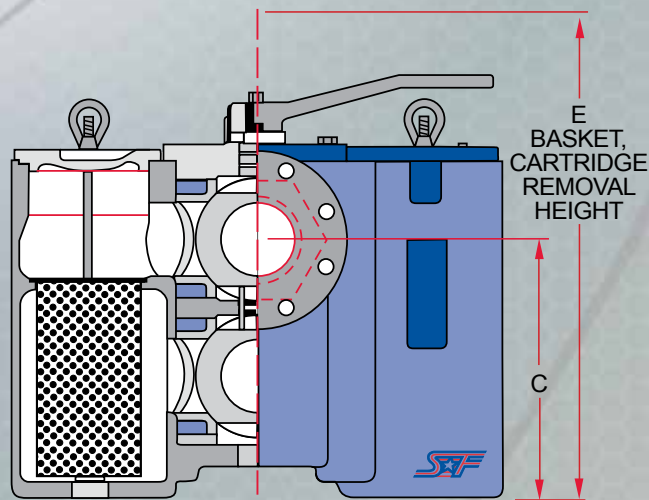

Dimensional Data (Inches)

Size		AF	AT	C	E	F	Shipping Weight (lbs.)					
							Cast Iron		Bronze		Carbon & SS	
Inches	Prefix						Flanged	Threaded	Flanged	Threaded	Flanged	Threaded
3/4	0075	-	5 1/2	5	13 3/8	10 1/2	-	45	-	56	-	52
1	0100	6 7/8	5 1/2	5	13 3/8	10 1/2	52	45	65	56	65	52
1 1/4	0125	6 7/8	7 1/2	6 13/16	17	13 1/4	-	90	-	115	-	110
1 1/2	0150	9 3/8	7 1/2	6 13/16	17	13 1/4	109	90	130	115	120	110
2	0200	10 5/8	10	8 3/8	21 3/4	17 3/8	190	180	230	220	210	195
2 1/2	0250	10 3/4	10	8 3/8	21 3/4	17 3/8	210	180	260	220	235	195
3	0300	13 1/2	-	8 7/8	26 1/2	22 3/4	340	-	380	-	460	-
4	0400	16	-	13 1/4	33	24 3/4	430	-	535	-	460	-

1/4" NPT cover vent taps are standard on all strainers.

1/4" NPT basket well drain connectors are standard on all strainer sizes.

Dimensions and weights are for reference only. Please contact Sure Flow Equipment Inc. for certified drawings.

# DUPLEX STRAINERS

**Cast Iron, Cast Steel and Cast 316SS, Cast Bronze  
Flanged (F) • Sizes 5", 6", 8"**

Type **DF125CI** Cast Iron; **DF150CS** Cast Steel; **DF150SS** Cast 316SS; **DF150BZ** Cast Bronze

The Sure Flow Duplex Strainer is a simple, economical, and trouble free design that has been time tested in applications around the world over many years. This type of strainer is actually a high quality, pressure rated plug valve with integral straining baskets.

Switching the flow from one basket to the other is accomplished by moving the operating handle through a 90 degree arc. The design is such that it is impossible for this operation to stop the flow because of the unique port design in the diverter plug. The entire switching operation takes less than 30 seconds. No tools are needed. The plug is automatically positioned each time in exactly the right spot by integral stops.



Before operating the handle a manual, integral lifting jack, built into the strainer is used to lift the diverter plug off of its seat. After the switching operation the lifting jack is used to reseat the plug. The lifting jack is specially designed to lift and seat the plug easily, even under high pressures. A built-in stop limits the distance the diverter plug can be raised. This minimizes the possibility of material bypassing the plug while it is rotated. It also prevents debris from building up under the plug and making it difficult to reseat.

Other important features of the Sure Flow Duplex Basket Strainers design include quick opening, swing away yoke design covers. No tools are required to remove the covers for quick and easy access to the strainer baskets, and they go back on just as fast as they came off.

Draining of the basket chambers is simplified with the standard NPT drain taps. All sizes are provided with mounting legs to bolt the strainer to the floor for a rock solid installation.

The Sure Flow Duplex Basket Strainer is your best choice for most applications. Its rugged design and ease of operation have made it the duplex strainer of choice around the world in hundreds of different industries.

**Sure Flow Duplex Strainer Selection Table (Sizes 5", 6", 8")**

Body Material	Connections	Sizes		Plug Material	Seals	Rating
		Inches	Prefix			
Iron (CI) Bronze (BZ)	Flanged CL.125	5, 6, 8	0500, 0600, 0800	Iron (CI) or Bronze (BZ)	Buna N	200 psig @ 100 °F 5" and 6" sizes
	Flanged CL.150	5, 6, 8	0500, 0600, 0800			
Carbon Steel (CS)	Flanged CL.150	6, 8	0600, 0800	Bronze (BZ) or Stainless Steel (SS)		150 psig @ 100 °F
Stainless Steel (SS)	Flanged CL.150	6, 8	0600, 0800	Stainless Steel (SS)	Viton®	8" size

**Cv Factors\***

Size	Value
5"	300
6"	420
8"	900

\* For water with clean perforated basket.

• **For Liquid Service** •  
5/32" SS perf basket  
standard for all sizes.

## Ordering Information

Example: Include full description

Size	Model	Screen
(Prefix)	Number	Opening
<b>0600</b>	<b>DF125CI</b>	<b>156</b>

### Notes:

Manufacturer reserves the right to modify dimensions, materials, or design. Please contact Sure Flow Equipment Inc. for certifications.

6" Flanged Duplex Strainer, Cast Iron,  
Class 125 ASME Flanges, 5/32" Perf Screen



**Sure flow  
Equipment Inc.**

Toll Free: 1-800-263-8251 Toll Free Fax: 1-800-876-1164  
International: 1-905-335-1350 International Fax: 1-905-332-4993  
Email: info@sureflowequipment.com www.sureflowequipment.com



# DUPLEX STRAINERS

## Options

- ▲ Ductile iron construction
- ▲ Basket perforations from 1/32" to 1/2"
- ▲ Basket mesh from 10 to 400
- ▲ Monel baskets
- ▲ Viton®, PTFE, or EPDM seals
- ▲ Vent valves
- ▲ Drain valves
- ▲ 1/4" NPT taps
- ▲ Magnetic basket inserts
- ▲ Pressure differential gauge and switch connections
- ▲ Steam jacket

## Dimensional Data (Inches)

Size		A	B	C	D	E	F	G	H	J	K	L	Shipping Weight (lbs.)			
Inches	Prefix												Cast Iron	Bronze	Carbon Steel	Stainless Steel
5	0500	18 3/8	9	9 3/4	33 1/4	14 3/4	10 1/4	17 3/16	3/8	19 3/4	9/16	41	463	473	-	-
6	0600	22	12 7/8	12 1/2	36 1/4	19 1/2	11 3/4	20 3/4	3/8	19 3/4	5/8	42	575	699	690	738
8	0800	25	14	17	50 5/8	23 1/16	-	30 3/4	1/2	28	15/16	56	1725	2070	1851	1920

Dimensions and weights are for reference only. Please contact Sure Flow Equipment Inc. for certified drawings.

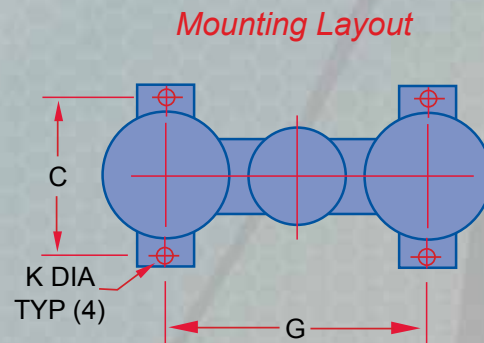
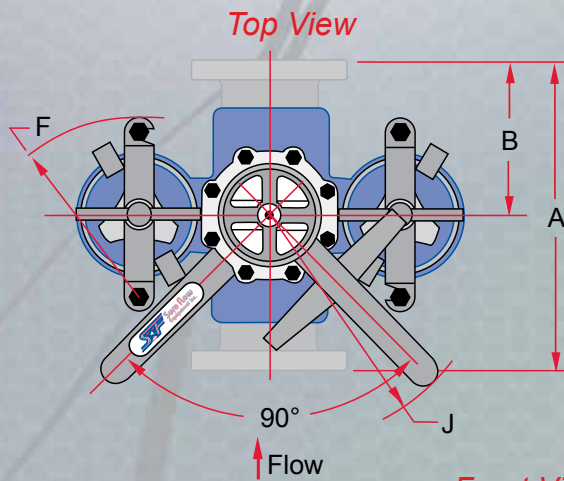

**Front View: Flanged - 5" to 8"**

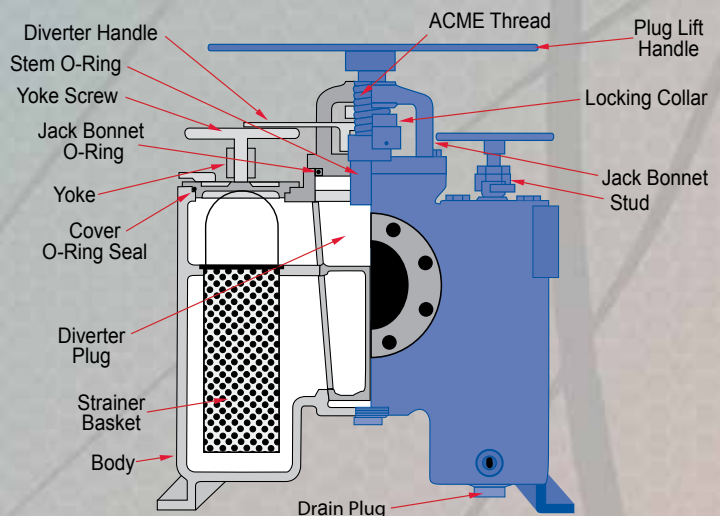
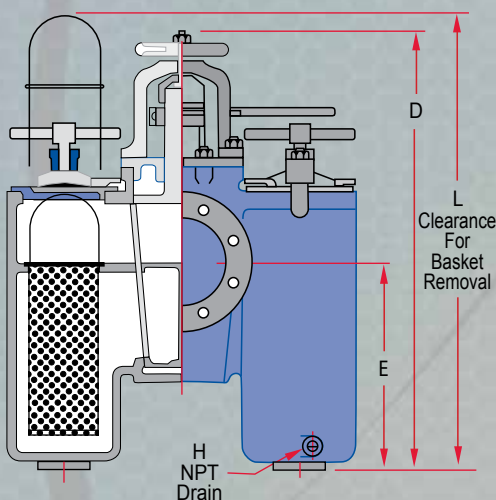

**Sure flow  
Equipment Inc.**

Toll Free: 1-800-263-8251 Toll Free Fax: 1-800-876-1164  
 International: 1-905-335-1350 International Fax: 1-905-332-4993  
 Email: info@sureflowequipment.com www.sureflowequipment.com



# DUPLEX STRAINERS

## Flow Rate Vs. Pressure Drop (Clean Screen)

These curves are for clean baskets, without mesh liners - and with WATER flowing through the strainer. For mesh-lined baskets and/or other fluids, you must first compute a correction factor.

### Model D125 and D150 Duplex - 3/4" Through 4"

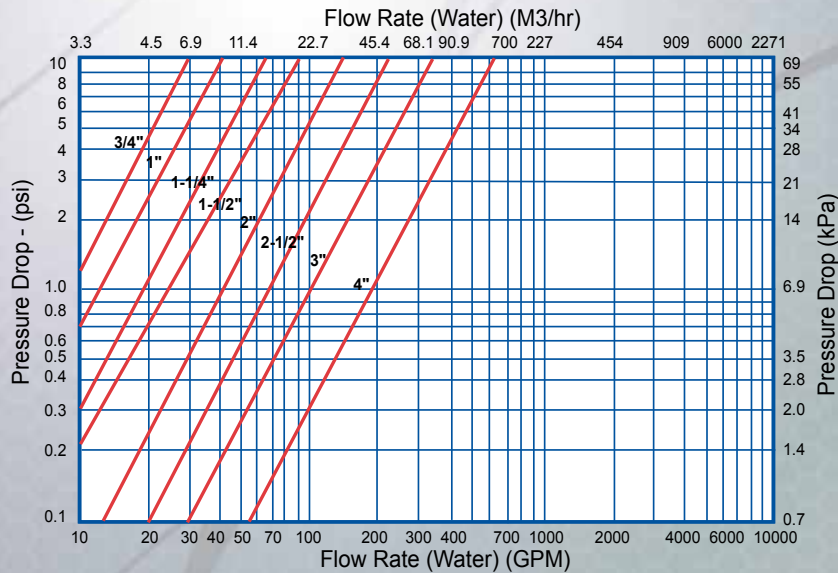

### Model DF125 and DF150 Duplex - 5" Through 8"

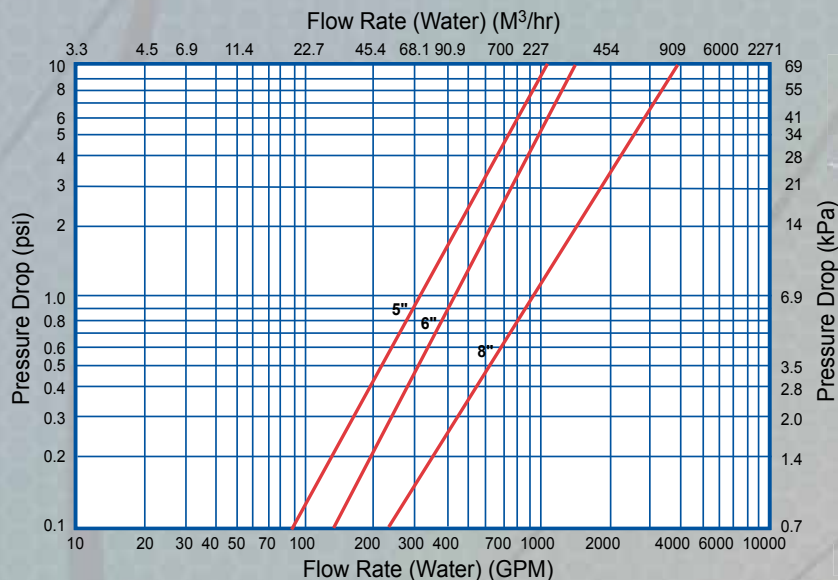

#### Notes:

Pressure drop curves are based on water flow with standard screens. For other fluids and/or screen openings, the figure shall be multiplied by the following correction factors.

These charts are for theoretical calculations **ONLY**.

Please contact our office with your exact specifications and you will be provided with factory calculations.



[www.sureflowequipment.com](http://www.sureflowequipment.com)

## Sure Flow Equipment Inc. – Limited Warranty

All products are warranted to be free of defects in material and workmanship for a period of one year from the date of shipment, subject to below. **All custom products are not subject to return, credit or refund.**

If the purchaser believes a product to be defective, the purchaser shall:

- (a) Notify the manufacturer **within ten(10) days after receipt of merchandise**, state the alleged defect and request permission to return the product. Merchandise will not be accepted for return without a "Return Code" clearly marked on the outside of the package. Contact the office to obtain a return code. **Merchandise will not be accepted for return or credit later than six (6) months after invoicing.**
- (b) If permission is given, return the product with the transportation prepaid. Collect shipments will not be accepted. Goods must be returned **prepaid**.

If a shipment is received in a damaged or deficient condition, a claim must be filed with the delivering carrier and noted on the freight bill before you accept the merchandise. All other claims must be made in writing and received by Sure Flow Equipment Inc. within ten (10) days after receipt of merchandise.

If the product is accepted for return and found to be defective, the manufacturer will, at its discretion, either repair or replace the product, F.O.B. factory, within 60 days of receipt, or issue credit for the purchase price.

Sure Flow Equipment Inc. shall not be liable for failure to deliver or delays in delivering occasioned by acts of God, war, labor difficulties, inability to obtain materials or any other causes whatsoever beyond our control.

Other than to repair, replace or credit as described above, purchaser agrees that manufacturer shall not be liable for any loss, costs, expenses, or damages of any kind arising out of the product, its use, installation or replacements, labeling, instructions, information or technical data of any kind, description of product use, sample or model, warnings or lack of any of the foregoing.

NO OTHER WARRANTIES, WRITTEN OR ORAL, EXPRESS OR IMPLIED, INCLUDING THE WARRANTIES OF FITNESS FOR A PARTICULAR PURPOSE AND MERCHANTABILITY, ARE MADE OR AUTHORIZED. NO AFFIRMATION OF ACT, PROMISE, DESCRIPTION OF PRODUCT OR USE OR SAMPLE OR MODEL SHALL CREATE ANY WARRANTY FROM MANUFACTURER, UNLESS SIGNED BY THE PRESIDENT OF MANUFACTURER.

### CANCELLATIONS:

Cancelled orders will be subject to a charge of at least 35%.

Cancelled custom orders will be subject to a charge of 100% of quoted price.

**MINIMUM BILLING: \$100.00 NET**

### SPECIAL DOCUMENTATION:

A charge will apply for non-standard, special documentation requests such as Material Test Reports (MTR's) and Certificates of Conformance (COC's).

Product shipping weights are approximate and subject to variances depending on packaging methods/requirements.



5010 North Service Rd.  
Burlington, ON L7L 5R5  
Tel: 905-335-1350  
Fax: 905-332-4993



P.O. Box 321  
Tonawanda, NY 14151-0321  
Tel: 1-800-263-8251  
Toll Free Fax: 1-800-876-1164

**Email:** [info@sureflowequipment.com](mailto:info@sureflowequipment.com)  
**Web Site:** [www.sureflowequipment.com](http://www.sureflowequipment.com)

**View our current catalogues online!**

Use your smartphone to scan this QR code and see what else Sure Flow has to offer.



June 2011