

BOLT AND STUD DIMENSIONS*

CONTINUED ON PAGE 23

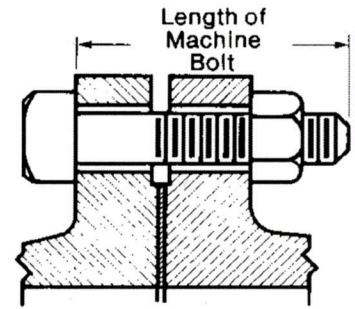

NPS DN	CLASS 150 (PN 20) FLANGES					CLASS 300 (PN 50) FLANGES					CLASS 400 (PN 64) FLANGES				
	NO. OF BOLTS	DIA. OF BOLTS (inches)	LENGTH			NO. OF BOLTS	DIA. OF BOLTS (inches)	LENGTH			NO. OF BOLTS	DIA. OF BOLTS (inches)	LENGTH OF STUD BOLTS		
			STUD BOLTS		MACHINE BOLTS			STUD BOLTS		MACHINE BOLTS			.25 6.4 RAISED FACE	MALE & FEMALE TONGUE & GROOVE	RING JOINT
			.06 1.6 RAISED FACE	RING JOINT	.06 1.6 RAISED FACE			.06 1.6 RAISED FACE	RING JOINT	.06 1.6 RAISED FACE					
1/2	4	1/2	2.50	-	2.00	4	1/2	2.75	3.00	2.25	4	1/2	3.25	3.00	3.00
15	4	1/2	65	-	50	4	1/2	70	75	55	4	1/2	85	75	75
3/4	4	1/2	2.50	-	2.25	4	5/8	3.00	3.50	2.50	4	5/8	3.50	3.25	3.50
20	4	1/2	65	-	55	4	5/8	75	90	6.5	4	5/8	90	85	90
1	4	1/2	2.75	3.25	2.25	4	5/8	3.25	3.75	2.75	4	5/8	3.75	3.50	3.75
25	4	1/2	70	85	55	4	5/8	85	95	70	4	5/8	95	90	95
1 1/4	4	1/2	2.75	3.25	2.50	4	5/8	3.25	3.75	2.75	4	5/8	4.00	3.75	4.00
32	4	1/2	70	85	65	4	5/8	85	95	70	4	5/8	100	95	100
1 1/2	4	1/2	3.00	3.50	2.50	4	3/4	3.75	4.25	3.00	4	3/4	4.25	4.00	4.25
40	4	1/2	75	90	65	4	3/4	95	110	75	4	3/4	110	100	110
2	4	5/8	3.25	3.75	2.75	8	5/8	3.50	4.25	3.00	8	5/8	4.25	4.00	4.50
50	4	5/8	85	95	70	8	5/8	90	110	75	8	5/8	110	100	115
2 1/2	4	5/8	3.50	4.00	3.00	8	3/4	4.00	4.75	3.50	8	3/4	4.75	4.50	5.00
65	4	5/8	90	100	75	8	3/4	100	120	90	8	3/4	120	115	130
3	4	5/8	3.75	4.25	3.25	8	3/4	4.25	5.00	3.75	8	3/4	5.00	4.75	5.25
80	4	5/8	95	110	85	8	3/4	110	125	95	8	3/4	130	120	135
3 1/2	8	5/8	3.75	4.25	3.25	8	3/4	4.50	5.25	3.75	8	7/8	5.50	5.25	5.75
90	8	5/8	95	110	85	8	3/4	115	135	95	8	7/8	140	135	145
4	8	5/8	3.75	4.25	3.25	8	3/4	4.50	5.25	4.00	8	7/8	5.50	5.25	5.75
100	8	5/8	95	110	85	8	3/4	115	135	100	8	7/8	140	135	145
5	8	3/4	4.00	4.50	3.25	8	3/4	4.75	5.50	4.25	8	7/8	5.75	5.50	6.00
125	8	3/4	100	115	85	8	3/4	120	140	110	8	7/8	145	140	155
6	8	3/4	4.00	4.50	3.50	12	3/4	5.00	5.75	4.25	12	7/8	6.00	5.75	6.25
150	8	3/4	100	115	90	12	3/4	130	145	110	12	7/8	155	145	160
8	8	3/4	4.25	4.75	3.75	12	7/8	5.50	6.25	4.75	12	1	6.75	6.50	7.00
200	8	3/4	110	120	95	12	7/8	140	160	120	12	1	175	165	180
10	12	7/8	4.75	5.25	4.00	16	1	6.25	7.00	5.50	16	1 1/8	7.50	7.25	7.75
250	12	7/8	120	135	100	16	1	160	180	140	16	1 1/8	190	185	195
12	12	7/8	4.75	5.25	4.25	16	1 1/8	6.75	7.50	6.00	16	1 1/4	8.00	7.75	8.25
300	12	7/8	120	135	110	16	1 1/8	175	190	155	16	1 1/4	205	195	210
14	12	1	5.25	4.75	4.50	20	1 1/8	7.00	7.75	6.25	20	1 1/4	8.25	8.00	8.50
350	12	1	135	145	115	20	1 1/8	180	195	160	20	1 1/4	210	205	215
16	16	1	5.50	6.00	4.75	20	1 1/4	7.50	8.25	6.50	20	1 3/8	8.75	8.50	9.00
400	16	1	140	155	120	20	1 1/4	190	210	165	20	1 3/8	225	215	230
18	16	1 1/8	6.00	6.50	5.00	24	1 1/4	7.75	8.50	6.75	24	1 3/8	9.00	8.75	9.25
450	16	1 1/8	150	165	125	24	1 1/4	195	215	175	24	1 3/8	230	225	235
20	20	1 1/8	6.25	6.75	5.50	24	1 1/4	8.25	9.00	7.25	24	1 1/2	9.75	9.50	10.00
500	20	1 1/8	160	175	140	24	1 1/4	210	230	185	24	1 1/2	250	240	255
24	20	1 1/4	7.00	7.50	6.00	24	1 1/2	9.25	10.25	8.00	24	1 3/4	10.75	10.50	11.25
600	20	1 1/4	180	190	155	24	1 1/2	235	260	205	24	1 3/4	275	265	285

* Length of Stud Bolt does not include the height of the points.

Bolt sizes are in inches.

Length of Male & Female and Tongue & Groove Stud Bolts are .25" (6.4 mm) less than those for the same size of .25"

(6.4 mm) Raised Face Stud Bolts.

INCHES
MILLIMETRES

BOLT AND STUD DIMENSIONS

CONTINUED

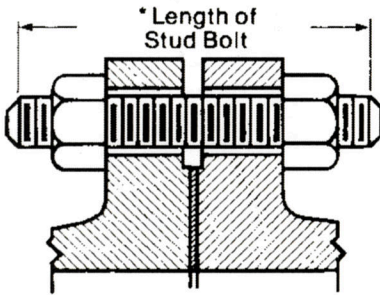

NPS	CLASS 600 (PN 100) FLANGES				CLASS 900 (PN 150) FLANGES				CLASS 1500 (PN 250) FLANGES				CLASS 2500 (PN 420) FLANGES				
	DN	NO. OF BOLTS	DIA. OF BOLTS (inches)	LENGTH OF STUD BOLTS		NO. OF BOLTS	DIA. OF BOLTS (inches)	LENGTH OF STUD BOLTS		NO. OF BOLTS	DIA. OF BOLTS (inches)	LENGTH OF STUD BOLTS		NO. OF BOLTS	DIA. OF BOLTS (inches)	LENGTH OF STUD BOLTS	
				.25 6.4 RAISED FACE	RING JOINT			.25 6.4 RAISED FACE	RING JOINT			.25 6.4 RAISED FACE	RING JOINT			.25 6.4 RAISED FACE	RING JOINT
1/2		4	1/2	3.25	3.00	4	3/4	4.25	4.25	4	3/4	4.25	4.25	4	3/4	5.25	5.25
	15	4	1/2	85	75	4	3/4	110	110	4	3/4	110	110	4	3/4	135	135
3/4		4	5/8	3.50	3.50	4	3/4	4.50	4.50	4	3/4	4.50	450	4	3/4	5.25	5.25
	20	4	5/8	90	90	4	3/4	115	115	4	3/4	115	115	4	3/4	135	135
1		4	5/8	3.75	3.75	4	7/8	5.00	5.00	4	7/8	5.00	5.00	4	7/8	5.75	5.75
	25	4	5/8	95	95	4	7/8	125	125	4	7/8	125	125	4	7/8	145	145
1 1/4		4	5/8	4.00	4.00	4	7/8	5.00	5.00	4	7/8	5.00	5.00	4	1	6.25	6.50
	32	4	5/8	100	100	4	7/8	125	125	4	7/8	125	125	4	1	160	165
1 1/2		4	3/4	4.25	4.25	4	1	5.50	5.50	4	1	5.50	5.50	4	1 1/8	7.00	7.25
	40	4	3/4	110	110	4	1	140	140	4	1	140	140	4	1 1/8	180	185
2		8	5/8	4.25	4.50	8	7/8	5.75	5.75	8	7/8	5.75	5.75	8	1	7.25	7.50
	50	8	5/8	110	115	8	7/8	145	145	8	7/8	145	145	8	1	185	190
2 1/2		8	3/4	4.75	5.00	8	1	6.25	6.25	8	1	6.25	6.25	8	1 1/8	8.00	8.25
	65	8	3/4	120	125	8	1	160	160	8	1	160	160	8	1 1/8	205	210
3		8	3/4	5.00	5.25	8	7/8	5.75	6.00	8	1 1/8	7.00	7.00	8	1 1/4	9.00	9.25
	80	8	3/4	130	135	8	7/8	145	155	8	1 1/8	180	180	8	1 1/4	230	235
3 1/2		8	7/8	5.50	5.75	-	-	-	-	-	-	-	-	-	-	-	-
	90	8	7/8	140	145	-	-	-	-	-	-	-	-	-	-	-	-
4		8	7/8	5.75	6.00	8	1 1/8	6.75	7.00	8	1 1/4	7.75	7.75	8	1 1/2	10.25	10.75
	100	8	7/8	145	155	8	1 1/8	175	180	8	1 1/4	195	195	8	1 1/2	260	275
5		8	1	6.50	6.75	8	1 1/4	7.50	7.75	8	1 1/2	9.75	9.75	8	1 3/4	12.00	12.75
	125	8	1	165	175	8	1 1/4	190	195	8	1 1/2	250	250	8	1 3/4	305	325
6		12	1	6.75	7.00	12	1 1/8	7.75	7.75	12	1 3/8	10.25	10.50	8	2	13.75	14.50
	150	12	1	175	180	12	1 1/8	195	195	12	1 3/8	260	265	8	2	350	370
8		12	1 1/8	7.75	7.75	12	1 3/8	8.75	9.00	12	1 5/8	11.50	12.00	12	2	15.25	16.00
	200	12	1 1/8	195	195	12	1 3/8	225	230	12	1 5/8	295	305	12	2	390	405
10		16	1 1/4	8.50	8.75	16	1 3/8	9.25	9.50	12	1 7/8	13.25	13.75	12	2 1/2	19.50	20.50
	250	16	1 1/4	215	225	16	1 3/8	235	240	12	1 7/8	335	350	12	2 1/2	495	520
12		20	1 1/4	8.75	9.00	20	1 3/8	10.00	10.25	16	2	14.75	15.50	12	2 3/4	21.50	22.50
	300	20	1 1/4	225	230	20	1 3/8	255	260	16	2	375	395	12	2 3/4	545	570
14		20	1 3/8	9.25	9.50	20	1 1/2	10.75	11.25	16	2 1/4	16.00	17.00				
	350	20	1 3/8	235	240	20	1 1/2	275	285	16	2 1/4	405	430				
16		20	1 1/2	10.00	10.25	20	1 5/8	11.25	11.75	16	2 1/2	17.50	18.50				
	400	20	1 1/2	255	260	20	1 5/8	285	300	16	2 1/2	445	470				
18		20	1 5/8	10.75	11.00	20	1 7/8	12.75	13.50	16	2 3/4	19.50	20.50				
	450	20	1 5/8	275	280	20	1 7/8	325	345	16	2 3/4	495	520				
20		24	1 5/8	11.50	11.75	20	2	13.50	14.25	16	3	21.50	22.50				
	500	24	1 5/8	295	300	20	2	345	360	16	3	545	570				
24		24	1 7/8	13.00	13.25	20	2 1/2	17.25	18.00	16	3 1/2	24.50	25.75				
	600	24	1 7/8	330	335	20	2 1/2	440	455	16	3 1/2	620	655				

* Length of Stud Bolt does not include the height of the points

Bolt sizes are in inches.

Length of Male & Female and Tongue & Groove Stud Bolts are .25" (6.4 mm) less than those for the same size of .25" (6.4 mm) Raised Face Stud Bolts.

INCHES
MILLIMETRES