

WATERWORKS



**Cast and fabricated waterworks fittings.
Proven and time tested.
Quality you can depend on.**



TABLE OF CONTENTS

TAB	SECTION CONTENTS	PAGE
0	Forward	0.1.1
1	Couplings, End Caps, Accessories and Fabricated Couplings	1.0.1
2	Service Saddles (Service and Isolating)	2.0.1
3	Sewer Saddles	3.0.1
4	Restraint Lugs, AWWA M-11 harness	4.0.1
5	Repair Clamps	5.0.1
6	Tapping Sleeves, Outlet Sleeves	6.0.1
7	Flanged Coupling Adapters Dismantling Joints	7.0.1
8	Expansion Joints	8.0.1
9	Miscellaneous (Drilling Machine, Meter Couplings, Adjustable Inserts, SLIKSTYX)	9.0.1
10	Installation Instructions	10.0.1

ROBAR INDUSTRIES LTD.

Surrey, British Columbia
Phone: 1-800-663-6553

Boucherville, Quebec
Phone: 1-800-315-9525

Calhoun, Georgia
Phone: 1-706-624-4404

Website: www.robarindustries.com / E-mail: waterworks@robarindustries.com



FORWARD

Table of Contents	0.0.1
Forward	0.1.1
Terms and Conditions	0.2.1
Warranty	0.3.1
ROBAR Standard Material Specifications	0.4.1
Gasket Selection Chart	0.5.1
Pipe Outside Diameter Chart (OD)	0.6.1
ROBAR Product Code Chart	0.7.1
Glossary	0.8.1

ROBAR INDUSTRIES LTD.

Surrey, British Columbia
Phone: 1-800-663-6553

Boucherville, Quebec
Phone: 1-800-315-9525

Calhoun, Georgia
Phone: 1-706-624-4404

Website: www.robarindustries.com / E-mail: waterworks@robarindustries.com



TERMS AND CONDITIONS

ROBAR, as used herein, means **Robar Industries Ltd.** a British Columbia corporation, **Les Produits Industriels Robar Inc.** a Quebec corporation and **Robar Distributors, Ltd.**, a Calhoun, GA corporation.

ENTIRE AGREEMENT. The terms and conditions stated herein constitute the entire agreement between the parties and any contrary or additional terms and conditions shall be of no effect unless agreed to in writing by an authorized officer of ROBAR. If these terms and conditions conflict with or are added to by any terms and condition of the purchaser's order, these terms and conditions will exclusively govern and will supersede the terms and conditions of the purchaser's order. Any change in these terms and conditions must be specifically agreed to in writing and signed by an authorized officer of ROBAR before becoming binding on ROBAR.

PRICES. All prices are stated F.O.B. ("Ex-Works ROBAR") ROBAR's shipping warehouse and are subject to change without notice. Prices in effect at time of shipping will apply unless a prior written quotation was obtained.

FREIGHT. All shipments to purchaser will be freight collect or prepaid-and-charge, unless the shipment qualifies for freight allowance as stated in the Freight Allowance Policy located in the price list.

TERMS OF PAYMENT. All invoices are due within 30 days. A 2% prompt pay discount may be calculated on the before-tax amount and deducted if paid within 20 days from date of invoice. A service charge of 2% per month, 24% per annum will be charged on all overdue accounts.

DELIVERIES AND DELAYS. ROBAR shall not be held liable for any delay or default in delivery of products arising out of or resulting from any cause beyond the control of ROBAR. This includes armed conflict or economic dislocation resulting therefrom; embargoes, shortage of labor or work stoppage beyond the control of ROBAR; shortages of raw materials, fuel, energy, production facilities or transportation; civil disorders of any kind; fires; floods; disaster and accidents. If such delays exceed 45 days, ROBAR may, by written notice to the purchaser, cancel the affected order as to any products then undelivered without liability. Any claim for shortages or damage in transit must be made directly with the carrier. Any claims for shortages of parts must be made within three days of receiving shipment and only if such shortages and/or damage are noted on the carrier's Bill of Lading.

TAXES. All prices are stated before taxes. Taxes will be added when applicable and are the responsibility of the purchaser.

RETURNED GOODS. Returned goods will not be accepted without prior authorization. All goods approved for return will be subject to a restocking charge, the amount of which will be determined after an evaluation of the customer's requested return. Products made to the purchaser's specification and requiring special materials or sizing may not be returned. Ask for ROBAR's returned goods policy.

CANCELLATION OF ORDERS. Any orders that are canceled will be subject to charges to the extent of the amount of labour and material already expended. Cancellation of orders already in transit will not be accepted and will be subject to the Returned Goods Policy stated above.

DISCLAIMER. ROBAR reserves the right to furnish substitutes for materials which cannot be reasonably obtained because of reasons beyond ROBAR's control.

TITLE AND RISK. Title and risk of loss or damage to the goods passes to the purchaser upon delivery to the carrier regardless of who arranges or pays for the shipping.

WARRANTY. (see ROBAR's Limited Warranty).

ROBAR INDUSTRIES LTD.

Surrey, British Columbia
Phone: 1-800-663-6553

Boucherville, Quebec
Phone: 1-800-315-9525

Calhoun, Georgia
Phone: 1-706-624-4404

Website: www.robarindustries.com / E-mail: waterworks@robarindustries.com



WARRANTY

LIMITED WARRANTY

All products manufactured and sold by ROBAR Industries Ltd. are warranted to be free from defects in material and factory workmanship for a period of one year from purchase. Under this warranty, ROBAR will, at its sole option, adjust, repair or replace the defective products or provide a full refund of the purchase price of the defective products.

ROBAR WILL NOT BE LIABLE FOR ANY CONSEQUENTIAL OR INCIDENTAL DAMAGES, LOSSES, OR EXPENSES, INCLUDING DAMAGE TO PROPERTY ARISING FROM ANY CAUSE.

All claims under this warranty must be made in writing immediately upon discovery of the product defect and sent to the Head Office of the company in Surrey, B.C., Canada. Any defective products must be held for inspection by a ROBAR representative.

ROBAR does not make any warranty of the merchantability or the fitness for a particular purpose of the products and/or parts manufactured and sold. Any references by ROBAR to the purchaser's specifications or requirements are strictly for identification purposes and the onus is entirely on the purchaser and/or the end user to select the appropriate product to fit an application. ROBAR does not warranty any products if they are used in an application other than what they are intended for or if they are misused.

This warranty is in lieu of all other warranties, whether express, implied or statutory, including any warranty of merchantability or fitness for a particular purpose. The purchaser's sole and exclusive remedy for any defective product is a claim under this warranty. This warranty may not be changed except by agreement in writing signed by an officer of ROBAR.

ROBAR INDUSTRIES LTD.

Surrey, British Columbia
Phone: 1-800-663-6553

Boucherville, Quebec
Phone: 1-800-315-9525

Calhoun, Georgia
Phone: 1-706-624-4404

Website: www.robarindustries.com / E-mail: waterworks@robarindustries.com



ROBAR STANDARD MATERIAL SPECIFICATIONS

The following standards are applicable to ROBAR products:

ANSI B16.5	Steel pipe flanges and flanged fittings.
ASTM A48	Standard specifications for gray iron castings.
ASTM A536	Standard specifications for ductile iron castings.
ASTM A743	Standard specifications for castings.
ASTM A781	Castings, steel and alloy, common requirements for general use.
ASTM D1330	Specifications for rubber gaskets.
ASTM F593	Stainless steel bolts, hex cap screws and studs.
ASTM F594	Stainless steel nuts.
AWWA C111	Rubber-gasket joints for ductile-iron pressure pipe and fittings.
AWWA C210	Liquid epoxy coating systems for the interior and exterior of steel water pipelines.
AWWA C213	Fusion bonded epoxy coating for the interior and exterior of steel water lines.
AWWA C219	Bolted, sleeve-type couplings for plain-end pipes.

Unless otherwise stated by Robar, all manufactured Robar products are rated for 150 PSI working pressure. Contact Robar for higher pressure ratings.



Tested and Certified by
WQA to NSF/ANSI 61

Only those products bearing the WQA mark are compliant.

ROBAR INDUSTRIES LTD.

Surrey, British Columbia
Phone: 1-800-663-6553

Boucherville, Quebec
Phone: 1-800-315-9525

Calhoun, Georgia
Phone: 1-706-624-4404

Website: www.robarindustries.com / E-mail: waterworks@robarindustries.com



GASKET SELECTION CHART

DESCRIPTION	MAXIMUM SERVICE TEMPERATURE ^{1,2,3}				COMMON USES
	MIN		MAX		
	°C	°F	°C	°F	
SBR ⁴ (Styrene Butadiene) (Buna S)	-30°	-22°	65°	150°	Freshwater, salt water, sanitary sewage.
Nitrile (NBR) ⁴ (Acrylonitrile Butadiene) (Buna N)	-30°	-22°	70°	160°	Freshwater, Hydrocarbons, fats, oils, greases, chemicals ⁴ . Natural Gas
Neoprene® (CR) (Polychloroprene)	-30°	-22°	70°	160°	Freshwater, salt water, sanitary sewage.
EPDM (Ethylene Propylene)	-40°	-40°	125°	250°	Freshwater, salt water, sanitary sewage, hot water.
Viton® ⁴ ; Fluorel® (FPM) ⁴ (Fluorocarbon)	-30°	-22°	150°	300°	Freshwater, Hydrocarbons, acids, vegetable oils, petroleum, Glycol.

- Note:
1. Maximum service temperatures listed are intended as general guidelines.
 2. For service temperatures greater than those listed, consult ROBAR for specific recommendations.
 3. Minimum service temperature is not usually a meaningful parameter for piping gaskets; however, low temperatures during pipeline installation may necessitate precautions. Consult ROBAR for pertinent recommendations.
 4. Not recommended for Toluene or Benzene.

ROBAR INDUSTRIES LTD.

Surrey, British Columbia
Phone: 1-800-663-6553

Boucherville, Quebec
Phone: 1-800-315-9525

Calhoun, Georgia
Phone: 1-706-624-4404

Website: www.robarindustries.com / E-mail: waterworks@robarindustries.com



PIPE OUTSIDE DIAMETER CHART (OD)

NOMINAL SIZE		STEEL SIZE		DUCTILE SIZE		CAST SIZE	SEWER PIPE	ASBESTOS CEMENT SIZE			
IN.	MM.	STD. STEEL	IPS PVC	C900 C905 PVC	DUCTILE IRON	CAST IRON	SDR35	A/C ME	A/C RB CLASS 100	A/C RB CLASS 150	A/C RB CLASS 200
2	50	2.38									
2.5	65	2.88									
3	75	3.50			3.80	3.96		3.74 (100) 3.84 (150)	3.93 - 3.95	4.03 - 4.13	4.17 - 4.29
4	100	4.50			4.80	5.00	4.21	4.64 (100) 4.81 (150)	4.70 - 5.26	4.97 - 5.32	5.22 - 5.57
6	150	6.63			6.90	7.10	6.28	6.91	7.05 - 7.48	7.10 - 7.43	7.23 - 7.60
8	200	8.63			9.05	9.30	8.40	9.11	9.22 - 9.75	9.39 - 9.75	9.39 - 9.81
10	250	10.75			11.10	11.40	10.50	10.89 - 11.66	11.25 - 11.83	11.85 - 12.26	11.77 - 12.31
12	300	12.75			13.20	13.50	12.50	12.99 - 13.92	13.37 - 14.10	14.10 - 14.35	14.03 - 14.55
14	350	14.00			15.30	15.65		15.07 - 16.22	15.26 - 15.89	16.41 - 16.85	16.41 - 16.95
16	400	16.00			17.40	17.80		17.15 - 18.62	17.34 - 18.03	18.62 - 19.20	18.65 - 19.30
18	450	18.00			19.50	19.92	18.70	19.90 - 22.18	20.55 - 20.65	21.26 - 22.5	19.80 - 23.14
20	500	20.00			21.60	22.06		22.12 - 24.66	22.68	22.96 - 23.64	25.02 - 25.42
24	600	24.00			25.80	26.32	24.80	26.48 - 29.62	27.15 - 27.30	28.32 - 28.75	29.98

IN.	MM.	STEEL	DUCTILE / C905	IN.	MM.	STEEL	DUCTILE / C905
30	750	30.00	32.00	48	1200	48.00	50.80
36	900	36.00	38.30	54	1370	54.00	57.56
42	1050	42.00	44.50	60	1524	60.00	61.60

ROBAR INDUSTRIES LTD.

Surrey, British Columbia
Phone: 1-800-663-6553

Boucherville, Quebec
Phone: 1-800-315-9525

Calhoun, Georgia
Phone: 1-706-624-4404

Website: www.robarindustries.com / E-mail: waterworks@robarindustries.com



ROBAR PRODUCT CODE TABLE

	1	4	0	8
	1st Digit Product Category Code	2nd Digit Material Code for Major Components	3rd Digit Special Requirements Code	4th Digit Fastener Material Code
0			No Special Requirements	No Fasteners
1	Coupling	Rubber	Cathodically Fitted	
2	Water Service Saddle		Special Requirements (Specify)	
3	Sewer Service Saddle			
4	Restraint Lug	Enamel Shop Coat Over Ductile Iron	Fabricated Reducing Coupling	Ductile Iron
5	Repair Clamp	Epoxy Coating Over Ductile Iron	Fabricated Long Barrel Coupling	Epoxy Coating Over Ductile Iron
6	Tapping Sleeves	Stainless Steel		Stainless Steel
7	Flange Coupling Adapter	Bronze Saddle or Wide Range Coupling		Epoxy Coating Over Mild Steel with Anodes
8	Expansion Joint	Enamel Shop Coat Over Carbon Steel	Isolation Feature	High Strength Low Alloy Steel
9	SS Pipe Insert	Epoxy Coating Over Carbon Steel	Wide Range Coupling	Epoxy Coating Over Mild Steel

Note: Not applicable to EBAA products and Arpol Products.

ROBAR Product Code:

ROBAR employs a brief product code for reasons of control and abbreviation. To interpret a code, ie "1408", read down each column and find the representative number. The number "1" in the first column represents a ROBAR coupling. The number "4" in the second column indicated that the majority of the product is made of enamel coated ductile iron. The number "0" in the third column states that there are no special requirements. The number "8" in the fourth column represents High Strength Low Alloy Steel as being the material used for the fasteners, ex. bolts, nuts, straps.

This chart will help define the quality ROBAR product best suited to fulfilling your waterworks requirements.

ROBAR INDUSTRIES LTD.

Surrey, British Columbia
Phone: 1-800-663-6553

Boucherville, Quebec
Phone: 1-800-315-9525

Calhoun, Georgia
Phone: 1-706-624-4404

Website: www.robarindustries.com / E-mail: waterworks@robarindustries.com



GLOSSARY

AC	Asbestos Cement
ASTM	American Society for Testing and Materials
ANODE	Made from an alloy that will generate current to protect the fitting from corrosion.
ANSI	American National Standards Institute
AWWA	American Water Works Association
BNQ	Bureau Normes De Quebec
CATHODICALLY PROTECTED	Designed for electrical continuity throughout the entire fitting. Such fittings are often used with sacrificial anodes for maximum galvanic and corrosion protection of the fitting.
CC	Corporation Thread (AWWA Taper thread)
CENTER SLEEVE	The center portion of a coupling. (Also called the barrel or center ring.)
DI	Ductile Iron
END RINGS	The part of a coupling that accepts bolts to apply thrust to the gasket creating a seal to the pipes being joined. (Also called the follower or end plate.)
EPDM	Ethylene Propylene
E/C	Electric Conductivity
HDPE	High Density Polyethylene
HSLA STEEL	High Strength Low Alloy Steel
ID	Inside Diameter
IP	Iron Pipe Thread
IPS	Iron Pipe Size
MS	Mild Steel
NBR (Buna N)	Acrylonitrile Butadiene (Rubber gasket material)
NC	National Coarse (In reference to thread pitch)
NSF	National Sanitation Foundation
OD	Outside Diameter
PICKLED / PASSIVATED	Chemically treating stainless steel after welding to return the stainless to its original appearance.
PSI	Pounds Per Square Inch
PVC	Polyvinyl Chloride
RB	Rough Barrel
SBR (Buna S)	Styrene Butadiene (Rubber gasket material)
SDR	Standard Dimension Ratio (Nominal pipe outside diameter/minimum wall thickness) - Generally associated with plastic pipe series.

ROBAR INDUSTRIES LTD.

Surrey, British Columbia
Phone: 1-800-663-6553

Boucherville, Quebec
Phone: 1-800-315-9525

Calhoun, Georgia
Phone: 1-706-624-4404

Website: www.robarindustries.com / E-mail: waterworks@robarindustries.com



SECTION 1 COUPLINGS

**Straight and Transition
Coupling Table**

Page 1.1.1

**Reducing
Coupling Table**

Page 1.2.1



**1408 / 1406
1408R / 1406R**

Page 1.3.1



**1508 / 1506
1508R / 1506R**

Page 1.4.1



**1507
1507R**

Page 1.5.1



**1519
1519R**

Page 1.6.1



**Multi-Fit
Couplings**

Page 1.7.1



1606

Page 1.11.1



Fabricated Couplings

**1808 / 1906
1848 / 1946
1858 / 1956**

Page 1.13.1



EBAA 3800

Page 1.14.1



Arpol

Page 1.15.1

ROBAR INDUSTRIES LTD.

Surrey, British Columbia
Phone: 1-800-663-6553

Boucherville, Quebec
Phone: 1-800-315-9525

Calhoun, Georgia
Phone: 1-706-624-4404

Website: www.robarindustries.com / E-mail: waterworks@robarindustries.com



CAST DUCTILE IRON COUPLINGS STRAIGHT & TRANSITION SELECTION TABLE

NOM. PIPE SIZE	FIRST END				BY X	SECOND END				MAX. PRESSURE (Working) LBS./IN. ²	NUMBER OF FASTENERS DIA. X LENGTH	SLEEVE LENGTH IN.	SHIPPING WEIGHT***	
	RANGE			END CODE		RANGE			END CODE				LBS.	KG.
	LOW	PIPE OD (Actual)	HIGH*			LOW	PIPE OD (Actual)	HIGH*						
2	2.35	2.38	2.63	D3	2	2.35	2.38	2.63	D3	175	2 5/8 x 8	5	10	4.5
2.5	2.69		2.88	D3	2.5	2.69		2.88	D3	175	2 5/8 x 8	5	13	6
4	3.45	3.50	3.60	4T	4	3.45	3.50	3.60	4T	175	4 5/8 x 8	5	17	7.7
	3.75		4.05	F3A		3.75		4.05	F3A					
	4.05		4.35	F3B		4.05		4.35	F3B		4 5/8 x 11	7	20	9.0
	4.40	4.50	4.60	D3		4.40	4.50	4.60	D3					
	4.74	4.80	5.10	A1		4.74	4.80	5.10	A1		4 5/8 x 14	10	28	13
	5.10		5.30	E5		5.10		5.30	E5					
6	5.65		5.95	6T	6	5.65		5.95	6T	175	5 5/8 x 8	5	25	11.3
	5.85		6.15	F3A		5.85		6.15	F3A					
	6.15		6.45	F3B		6.15		6.45	F3B		5 5/8 x 11	7	33	14.9
	6.50	6.63	6.70	D3		6.50	6.63	6.70	D3					
	6.86	6.90	7.10	A1		6.86	6.90	7.10	A1					
8	7.15		7.35	E5	8	7.15		7.35	E5	175	6 5/8 x 8	5	30	13.6
	7.90		8.25	F3A		7.90		8.25	F3A					
	8.25		8.55	F3B		8.25		8.55	F3B		6 5/8 x 11	7	39	17.7
	8.55	8.63	8.75	D3		8.55	8.63	8.75	D3					
	8.99	9.05	9.30	A1		8.99	9.05	9.30	A1					
10**	9.30		9.50	E5	10	9.30		9.50	E5	175	7 5/8 x 11	7	59	26.8
	9.85		10.20	F4A		9.85		10.20	F4A					
	10.20		10.50	F4B		10.20		10.50	F4B					
	10.60	10.75	10.90	D4		10.60	10.75	10.90	D4					
	11.10	11.10	11.40	B2		11.10	11.10	11.40	B2		7 5/8 x 14	10	75	34.0
	11.55		11.75	A1		11.55		11.75	A1					
	11.90		12.10	E5		11.90		12.10	E5					
SERIES 2 (STANDARD STEEL AND DUCTILE SIZES ONLY / PVC DR18)														
10	10.60	10.75	10.90	S9	10	10.60	10.75	10.90	S9	175	7 5/8 x 11	7	49	22.3
	11.10	11.10	11.40	G8		11.10	11.10	11.40	G8					

All dimensions are in inches.

CAST COUPLING CONFIGURATIONS:

- 1406:** Enamel coated Center Sleeve and End Rings, Stainless Steel Fasteners.
- 1408:** Enamel coated Center Sleeve and End Rings, HSLA Steel Fasteners.
- 1506:** Epoxy coated Center Sleeve and End Rings, Stainless Steel Fasteners.
- 1508:** Epoxy coated Center Sleeve and End Plates, HSLA steel fasteners.
- 1507:** Epoxy coated Center Sleeve and End Rings, HSLA Steel Bolts, complete with Zinc Anodes.
- 1519:** Epoxy coated Center Sleeve and End Plates, HSLA Steel Fasteners, complete with 1/4" Zinc plated cap screw designed for cathodically protected applications.

Note: * The pipe OD or the end plate combination code is used when ordering.
 ** Some transitions may require a stepped center sleeve.
 *** Shipping weights are approximate and vary according to configuration.
 - Recommended torque to 70-80 ft. lbs.



Couplings do not prevent pipe pullout. Suitable restraint should be used when required.

ROBAR INDUSTRIES LTD.

Surrey, British Columbia
Phone: 1-800-663-6553

Boucherville, Quebec
Phone: 1-800-315-9525

Calhoun, Georgia
Phone: 1-706-624-4404

Website: www.robarindustries.com / E-mail: waterworks@robarindustries.com



CAST DUCTILE IRON COUPLINGS STRAIGHT & TRANSITION SELECTION TABLE

NOM. PIPE SIZE	FIRST END				BY X	SECOND END				MAX. PRESSURE (Working) LBS./IN. ²	NUMBER OF FASTENERS DIA. X LENGTH	SLEEVE LENGTH IN.	SHIPPING WEIGHT***	
	RANGE			END CODE		RANGE			END CODE				LBS.	KG.
	LOW	PIPE OD (Actual)	HIGH*			LOW	PIPE OD (Actual)	HIGH*						
12**	12.00		12.30	F4A	X	12.00		12.30	F4A	175	8 5/8 x 11	7	74	33.6
	12.30		12.60	F4B		12.30		12.60	F4B					
	12.60	12.75	12.90	D4		12.60	12.75	12.90	D4					
	13.20	13.20	13.60	B2		13.20	13.20	13.60	B2					
	13.80	14.00	14.10	A1		13.80	14.00	14.10	A1					
	14.10		14.35	E5		14.10		14.35	E5					
SERIES 2 (STANDARD STEEL AND DUCTILE SIZES ONLY / PVC DR18)														
12	12.60	12.75	12.90	S9	X	12.60	12.75	12.90	S9	175	8 5/8 x 11	7	55	25.0
	13.20	13.20	13.50	G8		13.20	13.20	13.50	G8					
14	14.60		14.90	F2	X	14.60		14.90	F2	175	9 5/8 x 11	7	100	45.5
	15.30	15.30	15.70	B2		15.30	15.30	15.70	B2					
	15.80	16.00	16.25	A1		15.80	16.00	16.25	A1					
	16.40		16.80	E5		16.40		16.80	E5					
16	17.40	17.40	17.80	B2	X	17.40	17.40	17.80	B2	150	10 5/8 x 11	7	132	60
	17.80	18.00	18.20	A1		17.80	18.00	18.20	A1					
	18.40		18.80	E5		18.40		18.80	E5					
18	18.80		19.20	B1	X	18.80		19.20	B1	150	12 5/8 x 11	7	140	63.5
	19.10	19.50	19.70	A2		19.10	19.50	19.70	A2					
	19.70	20.00	20.25	E5		19.70	20.00	20.25	E5					
20	20.80		21.35	B1	X	20.80		21.35	B1	150	12 5/8 x 11	7	150	68
	21.35	21.60	21.75	A2		21.35	21.60	21.75	A2					
	21.75	22.00	22.25	E5		21.75	22.00	22.25	E5					
22	22.95		23.35	B1	X	22.95		23.35	B1	150	13 5/8 x 11	7	165	75
	23.45		23.85	A2		23.45		23.85	A2					
	23.75	24.00	24.25	E5		23.75	24.00	24.25	E5					
24	25.70	25.80	26.00	A2	X	25.70	25.80	26.00	A2	150	14 5/8 x 14	10	285	129.6
	26.10		26.32	E5		26.10		26.32	E5					

All dimensions are in inches.

HOW TO ORDER:

Determine the product number (1408, etc.) and the pipe OD or end plate combination for each end of the coupling (see page 1.1.1, 1.1.2), and then use the appropriate ordering code as shown in the following example.

To couple a 6" Steel pipe (6.63" OD) to a 6" C900 PVC pipe (6.90" OD), the ordering code is:

1408 - 6.63" x 6.90" i.e. **1408 - 6.63 x 6.90**
 product OD (Actual) OD (Actual) or **1408 - 6D3 x 6A1**
 number

- Note:
- * The pipe OD or the end plate combination code is used when ordering.
 - ** Some transitions may require a stepped center sleeve.
 - *** Shipping weights are approximate and vary according to configuration.
 - Recommended torque to 70-80 ft. lbs.

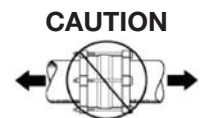

Couplings do not prevent pipe pullout. Suitable restraint should be used when required.

ROBAR INDUSTRIES LTD.

Surrey, British Columbia
Phone: 1-800-663-6553

Boucherville, Quebec
Phone: 1-800-315-9525

Calhoun, Georgia
Phone: 1-706-624-4404

Website: www.robarindustries.com / E-mail: waterworks@robarindustries.com



CAST DUCTILE IRON COUPLINGS

REDUCING COUPLING SELECTION TABLE

NOM. PIPE SIZE	LARGE END				BY X	SMALL END				MAX. PRESSURE (Working) LBS./IN. ²	NUMBER OF FASTENERS DIA. X LENGTH	SLEEVE LENGTH IN.	SHIPPING WEIGHT**	
	RANGE			END CODE		RANGE			END CODE				LBS.	KG.
	LOW	PIPE OD (Actual)	HIGH*			LOW	PIPE OD (Actual)	HIGH*						
6	5.65		5.95	6T	4	3.45	3.50	3.60	4T	175	5 5/8 x 8	5	25	11.3
	5.85		6.15	F3A		3.75		4.05	F3A					
	6.15		6.45	F3B		4.05		4.35	F3B					
	6.50	6.63	6.70	D3		4.40	4.50	4.60	D3					
	6.86	6.90	7.10	A1		4.74	4.80	5.10	A1					
	7.15		7.35	E5		5.10		5.30	E5					
8	7.90		8.25	F3A	6	5.85		6.15	F3A	175	6 5/8 x 8	5	34	15.5
	8.25		8.55	F3B		6.15		6.45	F3B					
	8.55	8.63	8.75	D3		6.50	6.63	6.70	D3					
	8.99	9.05	9.30	A1		6.86	6.90	7.10	A1					
	9.30		9.50	E5		7.15		7.35	E5					
10	9.85		10.20	F4A	8	7.90		8.25	F3A	175	7 5/8 x 11	7	51	23.2
	10.20		10.50	F4B		8.25		8.55	F3B					
	10.60	10.75	10.90	D4		8.55	8.63	8.75	D3					
	11.10	11.10	11.40	B2		8.99	9.05	9.30	A1					
	11.55		11.75	A1		9.30		9.50	E5					
	11.90		12.10	E5										
12	12.00		12.30	F4A	10	9.85		10.20	F4A	175	8 5/8 x 11	7	83	37.7
	12.30		12.60	F4B		10.20		10.50	F4B					
	12.60	12.75	12.90	D4		10.60	10.75	10.90	D4					
	13.20	13.20	13.60	B2		11.10	11.10	11.40	B2					
	13.80	14.00	14.10	A1		11.55		11.75	A1					
	14.10		14.35	E5		11.90		12.10	E5					
14	14.60		14.90	F2	12	12.00		12.30	F4A	175	9 5/8 x 11	7	111	50.5
	15.30	15.30	15.70	B2		12.30		12.60	F4B					
	15.80	16.00	16.25	A1		12.60	12.75	12.90	D4					
	16.40		16.80	E5		13.20	13.20	13.60	B2					
						13.80	14.00	14.10	A1					
						14.10		14.35	E5					

CAST COUPLING CONFIGURATIONS:

All dimensions are in inches.

- 1406R:** Enamel coated Center Sleeve and End Rings, Stainless Steel Fasteners.
- 1408R:** Enamel coated Center Sleeve and End Rings, HSLA Steel Fasteners.
- 1506R:** Epoxy coated Center Sleeve and End Rings, Stainless Steel Fasteners.
- 1507R:** Epoxy coated Center Sleeve and End Rings, Epoxy coated HSLA Steel Fasteners, complete with Zinc Anodes.
- 1508R:** Epoxy coated Center Sleeve and End Plates, HSLA steel fasteners.
- 1519R:** Epoxy coated Center Sleeve and End Rings, Epoxy coated HSLA Steel Fasteners, complete with 1/4" Zinc plated cap screw designed for cathodically protected applications.

Note: * The pipe OD or the end plate combination code is used when ordering.
 ** Shipping weights are approximate and vary according to configuration.
 - Recommended torque to 70-80 ft. lbs.

CAUTION



Couplings do not prevent pipe pullout. Suitable restraint should be used when required.

ROBAR INDUSTRIES LTD.

Surrey, British Columbia
Phone: 1-800-663-6553

Boucherville, Quebec
Phone: 1-800-315-9525

Calhoun, Georgia
Phone: 1-706-624-4404

Website: www.robarindustries.com / E-mail: waterworks@robarindustries.com



CAST DUCTILE IRON COUPLINGS REDUCING COUPLING SELECTION TABLE

NOM. PIPE SIZE	LARGE END				BY X	SMALL END				MAX. PRESSURE (Working) LBS./IN. ²	NUMBER OF FASTENERS DIA. X LENGTH	SLEEVE LENGTH IN.	SHIPPING WEIGHT**	
	RANGE			END CODE		RANGE			END CODE				LBS.	KG.
	LOW	PIPE OD (Actual)	HIGH*			LOW	PIPE OD (Actual)	HIGH*						
16					X	14.60		14.90	F2	150	10 5/8 x 11	7	124	56.4
	17.40	17.40	17.80	B2		15.30	15.30	15.70	B2					
	17.80	18.00	18.20	A1		15.80	16.00	16.25	A1					
	18.40		18.80	E5		16.40		16.80	E5					
18	18.80		19.20	B1	X	17.40	17.40	17.80	B2	150	12 5/8 x 11	7	124	60.0
	19.10	19.50	19.70	A2		17.80	18.00	18.20	A1					
	19.70	20.00	20.25	E5		18.40		18.80	E5					
20	20.80		21.35	B1	X	17.40	17.40	17.80	B2	150	12 5/8 x 11	7	161	73.2
	21.35	21.60	21.75	A2		17.80	18.00	18.20	A1					
	21.75	22.00	22.25	E5		18.40		18.80	E5					
20	20.80		21.35	B1	X	18.80		19.20	B1	150	12 5/8 x 11	7	156	70.9
	21.35	21.60	21.75	A2		19.10	19.50	19.70	A2					
	21.75	22.00	22.25	E5		19.70	20.00	20.25	E5					
22	22.95		23.35	B1	X	17.40	17.40	17.80	B2	150	13 5/8 x 11	7	272	123.6
	23.45		23.85	A2		17.80	18.00	18.20	A1					
	23.75	24.00	24.25	E5		18.40		18.80	E5					
22	22.95		23.35	B1	X	18.80		19.20	B1	150	13 5/8 x 11	7	268	121.8
	23.45		23.85	A2		19.10	19.50	19.70	A2					
	23.75	24.00	24.25	E5		19.70	20.00	20.25	E5					
22	22.95		23.35	B1	X	20.80		21.35	B1	150	13 5/8 x 11	7	275	125
	23.45		23.85	A2		21.35	21.60	21.75	A2					
	23.75	24.00	24.25	E5		21.75	22.00	22.25	E5					
24	25.70	25.80	26.00	A2	X	22.95		23.35	B1	150	14 5/8 x 14	10	300	136.4
	26.10		26.32	E5		23.45		23.85	A2					
						23.75	24.00	24.25	E5					

All dimensions are in inches.

HOW TO ORDER:

Determine the product number (**1408R, etc.**) and pipe OD or end plate combination for each end of the coupling (see page 1.2.1, 1.2.2), and then use the appropriate ordering code as shown in the following example.

To couple a 8" Ductile pipe (9.05" OD) to a 6" C900 PVC pipe (6.90" OD), the ordering code is:

1408R - 9.05" x 6.90" i.e. **1408R - 9.05 x 6.90**
 product OD (Actual) OD (Actual) or **1408R - 8A1 x 6A1**
 number

- Note:
- * The pipe OD or the end plate combination code is used when ordering.
 - ** Shipping weights are approximate and vary according to configuration.
 - Recommended torque to 70-80 ft. lbs.
 - Restraint is strongly recommended for reducing couplings.



Couplings do not prevent pipe pullout. Suitable restraint should be used when required.

ROBAR INDUSTRIES LTD.

Surrey, British Columbia
Phone: 1-800-663-6553

Boucherville, Quebec
Phone: 1-800-315-9525

Calhoun, Georgia
Phone: 1-706-624-4404

Website: www.robarindustries.com / E-mail: waterworks@robarindustries.com



1408 / 1406

CAST DUCTILE IRON COUPLING



APPLICATIONS:

ROBAR **1408 / 1406** Straight and Transition Couplings are used to make a non-restrained connection between two pipes of the same nominal size with same or different ODs. The **1406** is supplied with Stainless Steel fasteners.

MATERIAL SPECIFICATIONS:

Center Sleeve: Cast Ductile Iron.
 End Rings: Cast Ductile Iron.
 Gaskets: SBR (Buna S) Rubber.
 Other compounds available.
 Fasteners: **1408** - 5/8" NC HSLA Steel.
1406 - 5/8" NC T304 Stainless Steel.
 Nuts coated with anti-galling compound.
 Torque is 70-80 ft. lbs.
 Coating: Two coats of Enamel.

HOW TO ORDER:

Determine the product number (**1406, etc.**) and the pipe OD or end plate combination for each end of the coupling (see page 1.1.1, 1.1.2), and then use the appropriate ordering code as shown in the following example.

To couple a 6" Steel pipe (6.63" OD) to a 6" C900 PVC pipe (6.90" OD), using SS Bolts the ordering code is:

1406 - 6.63" x 6.90" i.e. **1406 - 6.63 x 6.90**
 product OD (Actual) OD (Actual) or **1406 - 6 D3 x A1**
 number



1408R / 1406R

CAST DUCTILE IRON REDUCING COUPLING



APPLICATIONS:

ROBAR **1408R / 1406R** Reducing Couplings are used to make a non-restrained connection between two pipes of different nominal sizes. The **1406R** is supplied with Stainless Steel fasteners.

MATERIAL SPECIFICATIONS:

Center Sleeve: Cast Ductile Iron.
 End Rings: Cast Ductile Iron.
 Gaskets: SBR (Buna S) Rubber.
 Other compounds available.
 Fasteners: **1408R** - 5/8" NC HSLA Steel.
1406R - 5/8" NC T304 Stainless Steel.
 Nuts coated with anti-galling compound.
 Torque is 70-80 ft. lbs.
 Coating: Two coats of Enamel.

HOW TO ORDER:

Determine the product number (**1406R, etc.**) and pipe OD or end plate combination for each end of the coupling (see page 1.2.1, 1.2.2), and then use the appropriate ordering code as shown in the following example.

To couple an 8" Ductile Iron pipe (9.05" OD) to a 6" C900 PVC pipe (6.90" OD) using SS Bolts, the ordering code is:

1406R - 9.05" x 6.90" i.e. **1406R - 9.05 x 6.90**
 product OD (Actual) OD (Actual) or **1406R - 8A1 x 6A1**
 number



These products are tested and certified by WQA to NSF/ANSI standard 61

CAUTION



Couplings do not prevent pipe pullout. Suitable restraint should be used when required.

ROBAR INDUSTRIES LTD.

Surrey, British Columbia
Phone: 1-800-663-6553

Boucherville, Quebec
Phone: 1-800-315-9525

Calhoun, Georgia
Phone: 1-706-624-4404

Website: www.robarindustries.com / E-mail: waterworks@robarindustries.com



1508 / 1506

CAST DUCTILE IRON COUPLING



APPLICATIONS:

ROBAR **1508 / 1506** Straight and Transition couplings are used to make a non-restrained connection between two pipes of the same nominal size but with same or different ODs. Used in areas where corrosion is a factor, the **1506** body is Epoxy coated with Stainless Steel fasteners.

MATERIAL SPECIFICATIONS:

Center Sleeve: Cast Ductile Iron.
 End Rings: Cast Ductile Iron.
 Gaskets: SBR (Buna S) Rubber.
 Other compounds available.

Fasteners: **1508** - 5/8" NC HSLA Steel.
1506 - 5/8" NC T304 Stainless Steel.
 Nuts coated with anti-galling compound.
 Torque is 70-80 ft. lbs.

Coating: Corrosion Protective Epoxy coating.

HOW TO ORDER:

Determine the product number (**1506, etc.**) and the pipe OD or end plate combination for each end of the coupling (see page 1.1.1, 1.1.2), and then use the appropriate ordering code as shown in the following example.

To couple a 6" Steel pipe (6.63" OD) to a 6" C900 PVC pipe (6.90" OD), using SS Bolts the ordering code is:

1506 - 6.63" x 6.90" i.e. **1506 - 6.63 x 6.90**
 product OD (Actual) OD (Actual) or **1506 - 6 D3 x A1**
 number



1508R / 1506R

CAST DUCTILE IRON REDUCING COUPLING



APPLICATIONS:

ROBAR **1508R / 1506R** Straight and Transition couplings are used to make a non-restrained connection between two pipes of the different nominal sizes. Used in areas where corrosion is a factor, the **1506R** body is Epoxy coated with Stainless Steel fasteners.

MATERIAL SPECIFICATIONS:

Center Sleeve: Cast Ductile Iron.
 End Rings: Cast Ductile Iron.
 Gaskets: SBR (Buna S) Rubber.
 Other compounds available.

Fasteners: **1508R** - 5/8" NC HSLA Steel.
1506R - 5/8" NC T304 Stainless Steel.
 Nuts coated with anti-galling compound.
 Torque is 70-80 ft. lbs.

Coating: Corrosion Protective Epoxy coating.

HOW TO ORDER:

Determine the product number (**1506R, etc.**) and pipe OD or end plate combination for each end of the coupling (see page 1.2.1, 1.2.2), and then use the appropriate ordering code as shown in the following example.

To couple an 8" Ductile Iron pipe (9.05" OD) to a 6" C900 PVC pipe (6.90" OD) using SS Bolts, the ordering code is:

1506R - 9.05" x 6.90" i.e. **1506R - 9.05 x 6.90**
 product OD (Actual) OD (Actual) or **1506R - 8A1 x 6A1**
 number



These products are tested and certified by WQA to NSF/ANSI standard 61

CAUTION



Couplings do not prevent pipe pullout. Suitable restraint should be used when required.

ROBAR INDUSTRIES LTD.

Surrey, British Columbia
Phone: 1-800-663-6553

Boucherville, Quebec
Phone: 1-800-315-9525

Calhoun, Georgia
Phone: 1-706-624-4404

Website: www.robarindustries.com / E-mail: waterworks@robarindustries.com



1507

CAST DUCTILE IRON COUPLING COMPLETE WITH ANODES



APPLICATIONS:

ROBAR **1507** Straight and Transition Couplings are used to make a non-restrained connection between two pipes of the same nominal size but with same or different ODs. Used in areas where corrosion is a factor, the **1507** body and fasteners are Epoxy coated. Zinc anodes are supplied with this coupling.

MATERIAL SPECIFICATIONS:

Center Sleeve: Cast Ductile Iron.
 End Rings: Cast Ductile Iron.
 Gaskets: SBR (Buna S) Rubber.
 Other compounds available.
 Fasteners: 5/8" NC HSLA Steel, Epoxy coated bolts.
 Torque is 70-80 ft. lbs.
 Coating: Corrosion Protective Epoxy coating.
 Anodes: Zinc 300 grams minimum.

HOW TO ORDER:

Determine the product number (**1507**) and the pipe OD or end plate combination for each end of the coupling (see page 1.1.1, 1.1.2), and then use the appropriate ordering code as shown in the following example.

To couple a 6" Steel pipe (6.63" OD) to a 6" C900 PVC pipe (6.90" OD), using MS Bolts with anodes, the ordering code is:

1507 - 6.63" x 6.90" i.e. **1507 - 6.63 x 6.90**
 product OD (Actual) OD (Actual) or **1507 - 6 D3 x A1**
 number

Note: - Coupling nuts are not Epoxy coated. We ensure continuity by removing the Epoxy coating from the underside of the bolt head and bolt head bearing surface of the end ring.



1507R

CAST DUCTILE IRON REDUCING COUPLING COMPLETE WITH ANODES



APPLICATIONS:

ROBAR **1507R** Reducing Couplings are used to make a connection between two pipes of different nominal sizes. Used in areas where corrosion is a factor, the **1507R** body and fasteners are Epoxy coated. Zinc anodes are supplied with this coupling.

MATERIAL SPECIFICATIONS:

Center Sleeve: Cast Ductile Iron.
 End Rings: Cast Ductile Iron.
 Gaskets: SBR (Buna S) Rubber.
 Other compounds available.
 Fasteners: 5/8" NC HSLA Steel, Epoxy coated bolts.
 Torque is 70-80 ft. lbs.
 Coating: Corrosion Protective Epoxy coating.
 Anodes: Zinc 300 grams minimum.

HOW TO ORDER:

Determine the product number (**1507R**) and pipe OD or end plate combination for each end of the coupling (see page 1.2.1, 1.2.2), and then use the appropriate ordering code as shown in the following example.

To couple an 8" Ductile Iron pipe (9.05" OD) to a 6" C900 PVC pipe (6.90" OD) using MS Bolts with anodes, the ordering code is:

1507R - 9.05" x 6.90" i.e. **1507R - 9.05 x 6.90**
 product OD (Actual) OD (Actual) or **1507R - 8A1 x 6A1**
 number

Note: - Coupling nuts are not Epoxy coated. We ensure continuity by removing the Epoxy coating from the underside of the bolt head and bolt head bearing surface of the end ring.



These products are tested and certified by WQA to NSF/ANSI standard 61

CAUTION



Couplings do not prevent pipe pullout. Suitable restraint should be used when required.

ROBAR INDUSTRIES LTD.

Surrey, British Columbia
Phone: 1-800-663-6553

Boucherville, Quebec
Phone: 1-800-315-9525

Calhoun, Georgia
Phone: 1-706-624-4404

Website: www.robarindustries.com / E-mail: waterworks@robarindustries.com



1519

CAST DUCTILE IRON COUPLING CATHODICALLY FITTED



APPLICATIONS:

ROBAR **1519** non-restrained Couplings are specially designed (cathodically fitted) to allow for electrical continuity throughout the entire fitting. Sacrificial anodes (not supplied) are recommended to protect the coupling assembly as long as “continuity” is maintained between the coupling components. To ensure “isolation” between metal pipes, the use of ROBAR **1180** Rubber Isolation Boot is recommended. (See “ROBAR **1180** Rubber Isolation Boot”, page 1.10.1). Isolation Boots are available in Straight, Transition or Reducing styles.

MATERIAL SPECIFICATIONS:

Center Sleeve: Cast Ductile Iron.
End Rings: Cast Ductile Iron.
Gaskets: SBR (Buna S) Rubber.
Other compounds available.
Fasteners: 5/8” NC HSLA Steel, Epoxy coated bolts.
1/4” Zinc plated cap screws.
Torque is 70-80 ft. lbs.
Coating: Corrosion Protective Epoxy coating.

HOW TO ORDER:

Determine the product number (**1519**) and the pipe OD or end plate combination for each end of the coupling (see page 1.1.1, 1.1.2), and then use the appropriate ordering code as shown in the following example.

To couple a 6” Steel pipe (6.63” OD) to a 6” DI pipe (6.90” OD), using MS Bolts and set screws the ordering code is:

1519 - 6.63” x 6.90” i.e. **1519 - 6.63 x 6.90**
product OD (Actual) OD (Actual) or **1519 - 6 D3 x A1**
number

Note: - Coupling nuts are not Epoxy coated. We ensure continuity by removing the Epoxy coating from the underside of the bolt head and bolt head bearing surface of the end ring.



1519R

CAST DUCTILE IRON REDUCING COUPLING CATHODICALLY FITTED



APPLICATIONS:

ROBAR **1519R** Reducing Couplings are used to make a non-restrained connection between two pipes of different nominal sizes. They are specially designed (cathodically fitted) to allow for electrical continuity throughout the entire fitting. Sacrificial anodes (not supplied) are recommended to protect the coupling assembly as long as “continuity” is maintained between the coupling components. To ensure “isolation” between metal pipes, the use of ROBAR **1180** Rubber Isolation Boot is recommended. (See “ROBAR **1180** Rubber Isolation Boot” product information sheet, page 1.10.1). Isolation Boots are available in Straight, Transition or Reducing styles.

MATERIAL SPECIFICATIONS:

Center Sleeve: Cast Ductile Iron.
End Rings: Cast Ductile Iron.
Gaskets: SBR (Buna S) Rubber.
Other compounds available.
Fasteners: 5/8” NC HSLA Steel, Epoxy coated bolts.
1/4” Zinc plated cap screws.
Torque is 70-80 ft. lbs.
Coating: Corrosion Protective Epoxy coating.

HOW TO ORDER:

Determine the product number (**1519R**) and the pipe OD or end plate combination for each end of the coupling (see page 1.2.1, 1.2.2), and then use the appropriate ordering code as shown in the following example.

To couple a 8” Steel pipe (8.63” OD) to a 6” DI pipe (6.90” OD), using MS Bolts and set screws the ordering code is:

1519R - 8.63” x 6.90” i.e. **1519R - 8.63 x 6.90**
product OD (Actual) OD (Actual) or **1519R - 8D3 x 6A1**
number

Note: - Coupling nuts are not Epoxy coated. We ensure continuity by removing the Epoxy coating from the underside of the bolt head and bolt head bearing surface of the end ring.



These products are tested and certified by WQA to NSF/ANSI standard 61

CAUTION



Couplings do not prevent pipe pullout. Suitable restraint should be used when required.

ROBAR INDUSTRIES LTD.

Surrey, British Columbia
Phone: 1-800-663-6553

Boucherville, Quebec
Phone: 1-800-315-9525

Calhoun, Georgia
Phone: 1-706-624-4404

Website: www.robarindustries.com / E-mail: waterworks@robarindustries.com



VANTAGE COUPLING



APPLICATIONS:

ROBAR **Vantage** couplings can be used to couple dissimilar ODs in the same nominal size group. The **Vantage** coupling comes with a stab-fit design, allowing for use on Ductile, Steel, PVC, HDPE, and AC pipe.

MATERIAL SPECIFICATIONS:

- Center Sleeve: Carbon Steel.
- End Rings: Cast Ductile Iron.
- Gaskets*: SBR (Buna S) Rubber. (other gasket material available upon request)
- Fasteners: **1498/1598** - 5/8" NC HSLA Steel.
1496/1596 - 5/8" T304 Stainless Steel.
Nuts coated with anti-galling compound.
Torque is 70 ft. lbs.
- Coating: **1498 /1496** - 2 coats of Enamel.
1598 /1596 - Corrosion Protective Epoxy coating.
- Options: **1696** - T-304 Stainless Steel center sleeve, end rings and fasteners with SBR gaskets.

HOW TO ORDER:

Determine the product number (**1596, etc.**), and order the nominal size you require and then use the appropriate ordering code as shown in the example.

To couple 6" steel pipe (6.63"OD) to a 6" ductile pipe (6.90"), using SS bolts and epoxy coating, the ordering code is:

1596 x 6" i.e. **1596 x 6**
product coupling
number range

NOMINAL SIZE	WORKING RANGE	BARREL LENGTH	NO. OF BOLTS	WEIGHT LBS.
4	4.50 - 5.60	8	3	24
6	6.63 - 7.60	8	3	32
8	8.63 - 9.80	8	3	39
10	10.75 - 12.26	12	4	74
12	12.75 - 14.40	12	5	106

All dimensions are in inches.

4 -10" Couplings rated for 175 PSI working pressure.

12" Couplings rated for 150 PSI working pressure.

CAUTION



Couplings do not prevent pipe pullout. Suitable restraint should be used when required.

- Note:
- The use of a pipe insert is required when installing coupling on HDPE.
 - Angular deflection up to 7° degrees.

ROBAR INDUSTRIES LTD.

Surrey, British Columbia
Phone: 1-800-663-6553

Boucherville, Quebec
Phone: 1-800-315-9525

Calhoun, Georgia
Phone: 1-706-624-4404

Website: www.robarindustries.com / E-mail: waterworks@robarindustries.com



STAB-FIT



APPLICATIONS:

ROBAR **Stab-Fit** couplings can be used to couple dissimilar ODs in the same nominal size group. The **Stab-Fit** coupling comes with a stab-fit design, allowing for use on Ductile Iron, Steel, PVC, HDPE, and Old Cast Iron pipe.

MATERIAL SPECIFICATIONS:

Center Sleeve: Cast Ductile Iron
 End Rings: Cast Ductile Iron.
 Gaskets: SBR.
 Fasteners: **1408SF/1508SF** - 5/8" NC HSLA Steel.
1406SF/1506SF - 5/8" T304 Stainless Steel.
 Nuts coated with anti-galling compound.
 Torque is 70 ft. lbs.
 Coating: **1408SF/1406SF** - 2 coats of Enamel.
1506SF/1508SF - Corrosion Protective Epoxy coating.

HOW TO ORDER:

Determine the product number (**1506SF**, etc.), and order the nominal size you require and then use the appropriate ordering code as shown in the example.

To couple 6" steel pipe (6.63"OD) to a 6" ductile pipe (6.90"), using SS bolts and epoxy coating, the ordering code is:

1506SF x 6" i.e. **1506SF x 6**
 product coupling
 number range

NOMINAL SIZE	WORKING RANGE	BARREL LENGTH	NO. OF BOLTS	WEIGHT LBS.
4	4.50 - 5.10	5	4	16
6	6.63 - 7.22	5	4	24
8	8.63 - 9.30	5	5	28
10	10.75 - 11.40	7	7	49
12	12.75 - 13.50	7	8	55

All dimensions are in inches.

Coupling rated for 150 PSI working pressure.

- Note:
- Available in 7" barrels
 - Stab-Fit design allows for installation without dis-assembly
 - The use of a pipe insert is required when installing coupling on HDPE.



These products are tested and certified by WQA to NSF/ANSI standard 61



Couplings do not prevent pipe pullout. Suitable restraint should be used when required.

ROBAR INDUSTRIES LTD.

Surrey, British Columbia
 Phone: 1-800-663-6553

Boucherville, Quebec
 Phone: 1-800-315-9525

Calhoun, Georgia
 Phone: 1-706-624-4404

Website: www.robarindustries.com / E-mail: waterworks@robarindustries.com



1728 / 1726

CAST DUCTILE IRON COUPLING MULTI-FIT



APPLICATIONS:

ROBAR **1728 / 1726** couplings are used to make a non-restrained connection between two pipes of the same nominal size but with same or different ODs. Up to 150 PSI working pressure. Angular deflection up to 8°. Stab Fit.

MATERIAL SPECIFICATIONS:

Center Sleeve: Cast Ductile Iron.
End Rings: Cast Ductile Iron.
Gaskets: SBR (Buna S).
Fasteners: **1728** - 5/8" Low Alloy Steel.
1726 - 5/8" T304 Stainless Steel.
Torque is 70-80 ft. lbs.
Coating: Fusion Bonded Epoxy Coated.

HOW TO ORDER:

Determine the product number (**1728**) and order the nominal size you require (see 1736AS chart below) and then use the appropriate ordering code as shown in the example.

To couple (using mild steel fasteners), a 4" steel pipe (4.50" OD) to an 4" AC pipe (5.25" OD), the ordering code is:

1728 x 4" i.e. **1728 x 6**
product coupling
number range

(See ordering chart below)

Note: - Lubricate Stainless Steel Bolts to prevent 'galling' of the Nuts.



1736AS

CAST STAINLESS STEEL COUPLING MULTI-FIT PLUS



APPLICATIONS:

ROBAR **1736AS** are 100% Stainless Steel couplings used to make a non-restrained connection between two pipes of the same nominal size but with same or different ODs. Up to 150 PSI working pressure. Angular deflection up to 8°. Stab Fit.

MATERIAL SPECIFICATIONS:

Center Sleeve: T304 Stainless Steel.
End Rings: T304 Stainless Steel.
Gaskets: SBR (Buna S).
Fasteners: 5/8" T304 Stainless Steel.
Torque is 70-80 ft. lbs.

HOW TO ORDER:

Determine the product number (**1736AS**) and order the nominal size you require (see below) and then use the appropriate ordering code as shown in the example.

To couple a 6" steel pipe (6.63" OD) to a 6" ductile pipe (6.90" OD), the ordering code is:

1736AS x 6" i.e. **1736AS x 6**
product coupling
number range

PIPE SIZES		PIPE OD RANGES		WEIGHTS		BARREL LENGTH		BOLT QTY
IN.	MM.	IN.	MM.	LBS.	KG.	IN.	MM.	
4	100	4.20 - 5.33	112 - 135	25	11	6	150	4
6	150	6.25 - 7.45	166 - 189	35	16	6	150	5
8	200	8.40 - 9.79	217 - 249	50	23	10	250	6
10	250	10.70 - 12.12	272 - 308	57	26	10	250	7
12	300	12.75 - 14.38	325 - 365	65	30	10	250	8



Note: - Lubricate Stainless Steel Bolts to prevent 'galling' of the Nuts.

Couplings do not prevent pipe pullout. Suitable restraint should be used when required.

ROBAR INDUSTRIES LTD.

Surrey, British Columbia
Phone: 1-800-663-6553

Boucherville, Quebec
Phone: 1-800-315-9525

Calhoun, Georgia
Phone: 1-706-624-4404

Website: www.robarindustries.com / E-mail: waterworks@robarindustries.com



1180

RUBBER ISOLATING BOOT

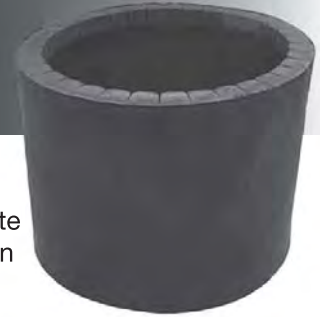

APPLICATIONS:

ROBAR **1180** Isolating Boots are used in conjunction with ROBAR couplings to separate pipe ends in cathodically protected systems. Can also be used to increase the OD of an existing pipe by 1/4". Isolating Boots are 6" long.

MATERIAL SPECIFICATIONS:

Boot: SBR (Buna S) Rubber compounded for water service and high dielectric value.

HOW TO ORDER:

Determine the product number (**1180**) and actual OD of the pipe to be isolated and then use the appropriate ordering code as shown in the following example.

For a 6" Ductile Iron Pipe (6.90" OD), the ordering code is:

1180 - 6.90" i.e. **1180 - 6.90**
product OD (Actual)
number



1410 / 1510

CAST DUCTILE IRON COUPLING END CAPS



APPLICATIONS:

ROBAR **1410/1510** End Caps are used in conjunction with a standard ROBAR Coupling (ordered separately) for the purpose of:

- Temporary stops for mains to be extended in future.
- Blind ending sections of main for testing.

The 2" IP outlet allows for:

- A 'take off' of 2" (or less) from the main.
- Air relief or overflow - top mount.
- Blow off or drainage - bottom mount.
- Chlorinating of lines.

NOMINAL PIPE SIZE	CAP OD	END ASSEMBLY	OUTLET PLUG QUANTITY	APPROXIMATE SHIPPING WEIGHT	
				LBS.	KG.
4	5.10	4A1	1	3.0	1.4
6	7.10	6A1	1	5.0	2.3
8	9.30	8A1	1	6.8	3.0
10	11.40	10B2	2	15.0	6.8
12	13.60	12B2	2	23.8	10.8

All dimensions are in inches.

MATERIAL SPECIFICATIONS:

Cap: Cast Ductile Iron
 Plug: Cast Iron - 2" IP square head.
 Coating: **1410** - Two coats of Enamel.
1510 - Corrosion Protective Epoxy coated.

HOW TO ORDER:

Determine the product number (**1410** or **1510**), nominal pipe size (see table above), and then use the appropriate ordering code as shown in the following example.

For an enamel coated 8" End Cap, the ordering code is:

1410 - 8" i.e. **1410 - 8**
product nominal
number pipe size

Note: - End capped couplings must be suitably blocked or restrained to resist hydraulic end thrust.

ROBAR INDUSTRIES LTD.

Surrey, British Columbia
Phone: 1-800-663-6553

Boucherville, Quebec
Phone: 1-800-315-9525

Calhoun, Georgia
Phone: 1-706-624-4404

Website: www.robarindustries.com / E-mail: waterworks@robarindustries.com



1606

FABRICATED STAINLESS STEEL COUPLING



APPLICATIONS:

ROBAR **1606** Couplings are used to make a non-restrained connection between pipes of the same outside diameter. This coupling is fabricated with a range of .30" (pipe OD \pm .15") and therefore is best suited for smooth pipe with a uniform outside diameter (ex. Steel, PVC, Ductile Iron and HDPE).

MATERIAL SPECIFICATIONS:

Body: T304 Stainless Steel, also available in T316 Stainless Steel*.
Gaskets: SBR (Buna S) Rubber. Other compounds available.
Fasteners: 5/8" NC T304 Stainless Steel*. Nuts coated with anti-galling compound. Torque is 70-80 ft. lbs.

HOW TO ORDER:

Determine the product number (**1606**), number of sections, actual pipe OD, coupling width (see chart below), and then order by using appropriate ordering code as shown in the following example.

If a two section (Style 2) coupling is required with a 12" body length, for a 10" Steel pipe (10.75" OD), the ordering code is:

1606 - 2 - 10.75" x 12" i.e. **1606 - 2 - 10.75 x 12**
product number number of sections OD (Actual) x coupling width

NOMINAL PIPE SIZE	MAX. PRESSURE (Working) LBS./IN. ²	APPROXIMATE SHIPPING WEIGHT (LBS.)					
		STYLE 1 6" SHELL	STYLE 1 12" SHELL	STYLE 2 12" SHELL	STYLE 3 12" SHELL	STYLE 3 18" SHELL	STYLE 3 24" SHELL
4	150	6 lbs.	11	16			
6	150	7 lbs.	12	17			
8	150	8 lbs.	13	18			
10	150		14	19			
12	150		16	24			
14	125		18	25			
16	100				34	46	68
18	100				35	46	69
20	100				37	48	72
22	100				39	50	78
24	100				41	52	84

All dimensions are in inches.

Available only in 6" increments.

- Note:
- * Refers to chemically treating Stainless Steel after welding ("Pickled/Passivated") to return it to its original appearance.
 - Other sizes and pressure ratings are available. Please contact ROBAR's Technical Sales Department for additional information.
 - Bolt Torque limit for all sizes is 80 ft./lbs.
 - Maximum working pressures are achieved with smooth OD pipes and with careful installation. Rough pipe surfaces and careless installation will reduce attainable pressures.
 - ROBAR **9626** Adjustable Stainless Steel Inserts are recommended for use on Polyethylene Pipe.
 - Refer to standards page.
 - 4.80" is the minimum OD **1606** Couplings can be sized to fit.
 - AWWA C219 does not apply to this coupling.

ROBAR INDUSTRIES LTD.

Surrey, British Columbia
Phone: 1-800-663-6553

Boucherville, Quebec
Phone: 1-800-315-9525

Calhoun, Georgia
Phone: 1-706-624-4404

Website: www.robarindustries.com / E-mail: waterworks@robarindustries.com



1808 / 1906

FABRICATED STEEL COUPLING - SERIES 200



APPLICATIONS:

ROBAR BAKER

Fabricated **1808 / 1906** Non-Restraining Couplings are used to flexibly couple larger diameter pipe. The **1906** is Epoxy coated with stainless steel fasteners. 4" through 120" available. Can be used to couple concrete pressure pipe together.

MATERIAL SPECIFICATIONS:

Center Sleeve: Carbon Steel.
 End Rings: Carbon Steel.
 Gaskets: SBR (Buna S) Rubber.
 Other compounds available.
 Fasteners: **1808/1908** - 5/8" NC HSLA Steel.
1806/1906 - 5/8" Stainless Steel.
 Nuts coated with anti-galling compound.
 Torque is 70-80 ft. lbs.
 Coating: **1806/1808** - Shop Coat.
1906/1908 - Epoxy coated - liquid or fusion.

HOW TO ORDER:

Determine the product number (**1808**), **actual pipe OD**, Center Sleeve thickness, Center Sleeve length and then use the appropriate ordering code (see chart below), as shown in the following example.

To couple an 18" Steel pipe (18.00" OD) with a 7" long by 1/4" thick Center Sleeve with shop coat and MS bolts, the ordering code is:

1808 - 18.00" - 1/4" x 7"
 product OD (Actual) thickness sleeve
 number length

i.e. **1808 - 18.00 - 1/4 x 7**

Couplings can be manufactured for any diameter. Examples below are Ductile and Steel ODs only. Couplings listed are for common sizes. Please contact ROBAR for sizes not listed below.

NOMINAL PIPE SIZE	OD PIPE	OVERALL OUTSIDE DIAMETER	CENTER SLEEVE T x L	FASTENERS NO. x DIA. x LENGTH	APPROXIMATE SHIPPING WEIGHT	
					LBS.	KG.
4	4.50	8.50	1/4 x 5	5/8 x 8	22	10
	4.80	9.17	1/4 x 5	5/8 x 8	22	10
6	6.63	11.00	1/4 x 7	5/8 x 11	26	12
	6.90	11.27	1/4 x 7	5/8 x 11	26	12
8	8.63	12.313	1/4 x 7	5/8 x 11	33	15
	9.05	12.563	1/4 x 7	5/8 x 11	33	15
10	10.75	14.438	1/4 x 7	5/8 x 11	40	18
	11.10	14.625	1/4 x 7	5/8 x 11	40	18
12	12.75	17.125	1/4 x 7	5/8 x 11	60	27
	13.20	17.563	1/4 x 7	5/8 x 11	66	30
14	14.00	18.375	1/4 x 7	5/8 x 11	80	36
	15.30	19.688	3/8 x 7	5/8 x 11	90	41
16	16.00	20.125	1/4 x 7	10 - 5/8 x 11	74	33.6
	17.40	21.75	3/8 x 7	10 - 5/8 x 11	87	39.6
18	18.00	22.125	1/4 x 7	10 - 5/8 x 11	81	36.8
	19.50	23.875	3/8 x 7	12 - 5/8 x 11	96	43.6
20	20.00	24.125	1/4 x 7	12 - 5/8 x 11	90	40.9
	21.60	26.00	3/8 x 7	12 - 5/8 x 11	107	48.6
24	24.00	28.125	1/4 x 7	14 - 5/8 x 11	107	48.6
	25.80	30.188	3/8 x 7	14 - 5/8 x 11	127	57.7
30	30.00	34.125	1/4 x 7	16 - 5/8 x 11	130	58.9
	32.00	36.375	3/8 x 7	16 - 5/8 x 11	156	71.2
36	36.00	40.125	1/4 x 7	18 - 5/8 x 11	155	70.30
	38.30	42.688	3/8 x 7	18 - 5/8 x 11	185	83.9

Larger sizes available

All dimensions are in inches.

CAUTION

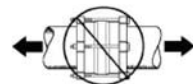

Couplings do not prevent pipe pullout. Suitable restraint should be used when required.

- Note:
- ROBAR inventories couplings in sizes 4" through 36" in both 1/4" and 3/8" thicknesses. A 1/4" thickness sleeve is used for Steel pipe ODs and 3/8" thickness sleeve is used for Ductile / C900 pipe ODs.
 - Couplings are fabricated to exact ODs.
 - Contact ROBAR for working pressures.

ROBAR INDUSTRIES LTD.

Surrey, British Columbia
Phone: 1-800-663-6553

Boucherville, Quebec
Phone: 1-800-315-9525

Calhoun, Georgia
Phone: 1-706-624-4404

Website: www.robarindustries.com / E-mail: waterworks@robarindustries.com



1848 / 1946 SERIES 220

FABRICATED STEEL REDUCING COUPLING



APPLICATIONS:

ROBAR  BAKER

Fabricated **1848 / 1946** Non-Restraining Steel Reducing Couplings are used to flexibly couple two pipes of different nominal size.

MATERIAL SPECIFICATIONS:

Center Sleeve: Carbon Steel.
 End Rings: Carbon Steel.
 Gaskets: SBR (Buna S) Rubber. Other compounds available.
 Fasteners: **1848** - 5/8" NC HSLA Steel. **1946** - T304 NC Stainless Steel. Nuts coated with anti-galling compound. Torque is 70-80 ft. lbs.
 Coating: **1848** - Shop Coat. **1946** - Epoxy Coat - liquid or fusion. (AWWA C210 or C213)

HOW TO ORDER:

Determine the product number (1848), Center Sleeve thickness, Center Sleeve length and then use the appropriate ordering code, as shown in the following example.

To couple a 16" Ductile pipe (17.40" OD) to a 16" Steel pipe with a 10" long by 1/4" thick Center Sleeve, the ordering code is:

1848 - 17.40" x 16.00" - 1/4" x 10"
 product OD (Actual) OD (Actual) thickness sleeve
 number length

i.e. **1848 - 17.40 x 16.00 - 1/4 x 10**

Note: - Reducing couplings are available with minimum barrel lengths of 10". - Contact ROBAR for working pressures.



1858 / 1956 SERIES 208

FABRICATED STEEL LONG SLEEVE COUPLING



APPLICATIONS:

ROBAR  BAKER

Fabricated **1858 / 1956** Long Sleeve Couplings are used to join large pipe gaps with the same ODs.

MATERIAL SPECIFICATIONS:

Center Sleeve: Carbon Steel.
 End Rings: Carbon Steel.
 Gaskets: SBR (Buna S) Rubber. Other compounds available.
 Fasteners: **1858** - 5/8" NC HSLA Steel. **1956** - T304 Stainless Steel. Nuts coated with anti-galling compound. Torque is 70-80 ft. lbs.
 Coating: **1858** - Shop Coat. **1956** - Epoxy Coated - liquid or fusion. (AWWA C210 or C213)

HOW TO ORDER:

Determine the product number (**1858, etc.**), **actual pipe OD of both pieces of pipe**, Center Sleeve thickness, Center Sleeve length and then use the appropriate ordering code, as shown in the following example.

To couple a 16" Ductile pipe (17.40" OD) to a 16" Ductile pipe with a 24" long by 1/4" thick Center Sleeve, the ordering code is:

1858 - 17.40" x 17.40" - 1/4" x 24"
 product OD (Actual) OD (Actual) thickness sleeve
 number length

i.e. **1858 - 17.40 x 17.40 - 1/4 x 24**

Note: - Please contact ROBAR for special lengths and dimensions. - Contact ROBAR for working pressures.



Couplings do not prevent pipe pullout. Suitable restraint should be used when required.

ROBAR INDUSTRIES LTD.

Surrey, British Columbia
 Phone: 1-800-663-6553

Boucherville, Quebec
 Phone: 1-800-315-9525

Calhoun, Georgia
 Phone: 1-706-624-4404

Website: www.robarindustries.com / E-mail: waterworks@robarindustries.com



EBAA 3800 SERIES

RESTRAINED COUPLING



APPLICATIONS:

ROBAR EBAA

The **3800** Series Restrained Coupling is used for joining and restraining two plain end pipes of the same or dissimilar materials (Ductile Iron pipe, PVC pipe, Steel pipe and/or High Density Polyethylene Pipe (HDPE)). The coupling provides axial restraint to the rated pressure listed below, with a minimum factor of safety of 2:1. The **3800** Series Coupling is an economical alternative to the harnessing of unrestrained repair type couplings. The **3800** Series Coupling meets or exceeds AWWA C219 standards.

MATERIAL SPECIFICATIONS:

Center Sleeve: ASTM A536 Ductile Iron.
 End Rings: ASTM A536 Ductile Iron.
 Gaskets: SBR (Buna S) Rubber.
 Fasteners: Corrosion Resistant, HSLA steel bolts & nuts.
 T304 Stainless Steel available.
 Torque is 60-75 ft. lbs.
 Coating: Barrel - Fusion Bond Epoxy
 Restraint Gland - Megabond® coated

HOW TO ORDER:

Determine the product number (**3806**) and the OD for each end of the coupling and then use the appropriate ordering code as shown in the following example.

To couple a 6" Steel pipe (6.63" OD) to a 6" C900 PVC pipe (6.90" OD), the ordering code is:

3806 6.63" 6.90"
 product OD (Actual) OD (Actual)
 number

i.e. **3806 - 6.63 x 6.90**

NOMINAL PIPE SIZE	SERIES NO.	APPROXIMATE SHIPPING WEIGHT		NO. OF WEDGES	DESIGN DEFLECTION	BARREL LENGTH	NO. OF THRUST BOLTS	DIA. OF THRUST BOLTS
		LBS.	KG.					
4	3804	36	16	2	5°	7.5	4	3/4 x 14
6	3806	50	23	4			6	
8	3808	68	31	4			6	
10	3810	85	39	6			8	
12	3812	104	47	6			8	

All dimensions are in inches.

PRESSURE RATINGS (PSI)									
NOMINAL PIPE SIZE	SERIES NO.	DUCTILE IRON PIPE	STEEL PIPE	HDPE Pipe			C900 PVC Pipe		
				DR 11 CLASS 160	DR 13.5 CLASS 130	DR 17 CLASS 100	DR 14 CLASS 200	DR 18 CLASS 150	DR 25 CLASS 100
4	3804	250	250	160	130	100	200	150	100
6	3806	250	250	160	130	100	200	150	100
8	3808	250	250	160	130	100	200	150	100
10	3810	250	250	160	130	100	200	150	100
12	3812	250	250	160	130	100	200	150	100

Note: * A pipe wall stiffening insert is required for use on HDPE pipe. The stiffener must be sized to encompass the entire bearing length of the restraint devices.

ROBAR INDUSTRIES LTD.

Surrey, British Columbia
 Phone: 1-800-663-6553

Boucherville, Quebec
 Phone: 1-800-315-9525

Calhoun, Georgia
 Phone: 1-706-624-4404

Website: www.robarindustries.com / E-mail: waterworks@robarindustries.com



ARPOL

COUPLINGS



APPLICATIONS:

Flexible stainless steel couplings for the connection of Steel, Cast & Ductile Iron, PVC, HDPE, AC and FRP pipe. Suitable for water, sewer, gas, oil and hydrocarbons.

MATERIAL SPECIFICATIONS:

Casing:	Stainless Steel AISI 304L (316L available)
Locking Bolts:	Stainless Steel AISI 316 (available in carbon steel dacromet coated)
Locking Bars:	Stainless Steel AISI 304L or 316L (available in carbon steel dacromet coated)
Inner Steel Bridge:	Stainless Steel AISI 304L or 316L
Inner Rings:	Stainless Steel
Rubber Sealing Gasket:	EPDM (ethylene-propylene) Suitable for water, air and chemical products Temperature range: -20C - +100C Other materials and temperature ranges available



ARPOL INSTALL

Flexible coupling for pipe connections



ARPOL TRANS

Flexible coupling for connecting pipes with different outside diameters

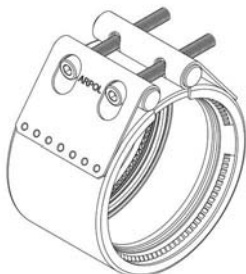

ARPOL FIX

Flexible coupling for pipe connections with axial restraint

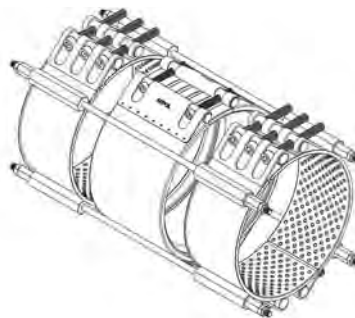

ARPOL MULTI-FIX

Anchoring system to restrain HDPE pipes



ARPOL REPAIR

Flexible coupling for pipe repair

Please contact Robar for additional information

ROBAR INDUSTRIES LTD.

Surrey, British Columbia
Phone: 1-800-663-6553

Boucherville, Quebec
Phone: 1-800-315-9525

Calhoun, Georgia
Phone: 1-706-624-4404

Website: www.robarindustries.com / E-mail: waterworks@robarindustries.com



SECTION 2 SERVICE SADDLES



2408
2508

Page 2.1.1



2406
2506

Page 2.2.1



2616
2626
2636

Page 2.3.1



2706

Page 2.4.1



2786

Page 2.5.1



2996

Page 2.6.1

ROBAR INDUSTRIES LTD.

Surrey, British Columbia
Phone: 1-800-663-6553

Boucherville, Quebec
Phone: 1-800-315-9525

Calhoun, Georgia
Phone: 1-706-624-4404

Website: www.robarindustries.com / E-mail: waterworks@robarindustries.com



2408 / 2508

CAST DUCTILE IRON SERVICE SADDLE



APPLICATIONS:

ROBAR **2408 / 2508** Service Saddles are used to take a service outlet off a transmission or distribution line. The **2408** Service Saddle is recommended for use on Ductile Iron pipe and Steel pipe. Not suitable for Plastic pipe. The **2408** comes with shop coat and the **2508** comes fusion bonded epoxy. Both saddles come with low alloy steel straps.

MATERIAL SPECIFICATIONS:

Saddle Body: Cast Ductile Iron body.
Gaskets: SBR (Buna S) Rubber.
Other compounds available.
Saddle Straps: 5/8" NC Low Alloy Steel, U-bolt.
Fasteners: 5/8" NC HSLA. Zinc plated.
Torque is 70-80 ft. lbs.
Coating: **2408** - Two coats of Enamel.
2508 - Fusion Bonded Epoxy.

Designed for tapping into Steel, Ductile Iron and Cast Iron pipe. Saddle straps and bodies are shaped to evenly and safely distribute the clamping load to the pipe. When tightened, they conform to the various diameters in each nominal size of pipe within specified working range. Refer to the ROBAR OD Chart (see page 0.6.1) for various pipe diameters.

HOW TO ORDER:

Determine the product number (**2408, etc.**), the nominal pipe size, outlet size, outlet thread, and strap style, and then use the appropriate ordering code as shown in the following example:

If a 6" Double strap saddle is required with a 2" CC tap to fit 6" Ductile pipe (6.90"OD), the ordering code is:

2408 - 6" x 2 - CC - DS
product nominal tap CC DS
number size style strap
pipe

i.e. **2408 - 6 x 2 - CC - DS**

NOMINAL PIPE SIZE	WORKING RANGE		OUTLET SIZES AWWA (CC) OR IRON PIPE (IP)	STRAP STYLE		APPROXIMATE SHIPPING WEIGHT	
	LOW	HIGH		SINGLE (SS)	DOUBLE (DS)	LBS.	KG.
4	4.50	5.40	3/4 - 2	SS		5.0	2.3
					DS	6.5	2.9
6	6.62	7.50	3/4 - 2	SS		6.0	2.7
					DS	8.5	3.9
8	8.62	9.62	3/4 - 2	SS		6.5	2.9
					DS	10.0	4.5
10	10.75	12.12	3/4 - 2	SS		7.5	3.4
					DS	11.5	5.2
12	12.75	14.38	3/4 - 2	SS		11.5	5.2
					DS	12.5	5.7
14	15.15	16.00	3/4 - 2		DS	15	6.8
					DS	19	8.6
16	17.25	17.80	3/4 - 2		DS		
	17.80	18.00			DS		

All dimensions are in inches.

Note: - Alternative gasket materials are available. Refer to the Gasket Selection Chart and contact ROBAR for pricing and delivery.



This product is tested and certified by WQA to NSF/ANSI standard 61

ROBAR INDUSTRIES LTD.

Surrey, British Columbia
Phone: 1-800-663-6553

Boucherville, Quebec
Phone: 1-800-315-9525

Calhoun, Georgia
Phone: 1-706-624-4404

Website: www.robarindustries.com / E-mail: waterworks@robarindustries.com



2406 / 2506

CAST DUCTILE IRON SERVICE SADDLE



APPLICATIONS:

ROBAR **2406 / 2506** Service Saddles are used to take a service outlet off a transmission or distribution line. The **2406 / 2506** are suitable for use on C900 pipe due to their wide strap configuration. The **2406** comes with shop coat and the **2506** comes with fusion bonded epoxy coated. The **2406 / 2506** comes with Stainless Steel straps.

MATERIAL SPECIFICATIONS:

Saddle Body: Cast Ductile Iron body.
 Gaskets: SBR (Buna S) Rubber.
 Other compounds available.
 Saddle Straps: 1/2" NC T304 Stainless Steel*.
 Fasteners: 1/2" T304 Stainless Steel*.
 Nuts coated with anti-galling compound.
 Torque is 45 ft/lbs.
 Coating: **2406** - Two coats of Enamel.
2506 - Fusion Bonded Epoxy.

HOW TO ORDER:

Determine the product number (**2406, etc.**), the nominal pipe size, outlet size, outlet thread, and strap style, and then use the appropriate ordering code as shown in the following example:

If a 6" Double strap saddle is required with a 2" CC tap to fit 6" Ductile pipe (6.90"OD), the ordering code is:

2406 - 6" x 2 - CC - DS
 product nominal tap tap strap
 number pipe size style style

i.e. **2406 - 6 x 2 - CC - DS**

Designed for tapping into Steel, Ductile Iron, Cast Iron and C900 PVC pipe. Saddle straps and bodies are shaped to evenly and safely distribute the clamping load to the pipe. When tightened, they conform to the various diameters in each nominal size of pipe within specified working range. Refer to the ROBAR OD Chart (see page 0.6.1) for various pipe diameters.

NOMINAL PIPE SIZE	WORKING RANGE		OUTLET SIZES AWWA (CC) OR IRON PIPE (IP)	STRAP STYLE		APPROXIMATE SHIPPING WEIGHT	
	LOW	HIGH		SINGLE (SS)	DOUBLE (DS)	LBS.	KG.
2	2.38	2.56	3/4 - 1	SS		2.0	0.9
3	3.25	3.54	3/4 - 1	SS		2.5	1.1
4	4.50	5.40	3/4 - 2	SS		5.0	2.3
					DS	6.5	2.9
6	6.62	7.50	3/4 - 2	SS		6.0	2.7
					DS	8.5	3.9
8	8.62	9.62	3/4 - 2	SS		6.5	2.9
					DS	10.0	4.5
10	10.75	12.12	3/4 - 2	SS		7.5	3.4
					DS	11.5	5.2
12	12.75	14.38	3/4 - 2	SS		11.5	5.2
					DS	12.5	5.7
14	15.15	16.00	3/4 - 2		DS	15	6.8
				17.25	17.80	3/4 - 2	
17.80	18.00						

All dimensions are in inches.

Note: * Refers to chemically treating Stainless Steel after welding ("Pickled/Passivated") to return it to its original appearance.
 - Alternative gasket materials are available. Refer to the Gasket Selection Chart and contact ROBAR for pricing and delivery.



This product is tested and certified by WQA to NSF/ANSI standard 61

ROBAR INDUSTRIES LTD.

Surrey, British Columbia
Phone: 1-800-663-6553

Boucherville, Quebec
Phone: 1-800-315-9525

Calhoun, Georgia
Phone: 1-706-624-4404

Website: www.robarindustries.com / E-mail: waterworks@robarindustries.com



2616 / 2626 / 2636

FABRICATED STAINLESS STEEL SERVICE SADDLE - SERIES 2606

APPLICATIONS:

ROBAR **2606** Service Saddles are used to take a service outlet off any transmission or distribution supply line. Especially recommended for Plastic pipe or where corrosion is a factor. Can be used on Ductile, Steel, HDPE, and AC pipe.

MATERIAL SPECIFICATIONS:

Saddle Body: T304 Stainless Steel, fully passivated*.
Gasket: SBR (Buna S) Rubber.
Robar "Boss Pad" Gasket.
Other compounds available**.
Fasteners: 5/8" NC T304 Stainless Steel studs,
rolled threads, fully passivated*.
Nuts coated with anti-galling compound.

HOW TO ORDER:

Determine the product number (**2616, etc.**), the actual OD, (see Table on pages 2.3.2, 2.3.3 and 2.3.4), outlet size, outlet thread, and bolt style, and then use the appropriate ordering code as shown in the following examples. If a double bolt (DB) saddle with a 3/4" cc tap is required on a 6" Ductile Iron pipe (6.90), the ordering code is:

2616 - 7.00" x 3/4" - CC - DB
product high limit of outlet outlet bolt style
number range size thread

i.e. **2616 - 7.00 x 3/4 - CC - DB**

OPTIONS:

- 2 1/2" and 3" IP outlets are available on nominal sizes 6" and larger on **2626** and **2636** saddles only.
- Saddle body can be made wider if required.



2616 (1 Section)

- Double bolt closures (DB) on 2" through 12" nominal pipe sizes.



2626 (2 Sections)

- Double (DB) bolt closures on 4" through 18" nominal pipe sizes.



2636 (3 Sections)

- Double (DB) bolt closures on 16" through 30" nominal pipe sizes.

Note: * Refers to chemically treating Stainless Steel after welding ("Pickled/Passivated") to return it to its original appearance.

** Alternative gasket materials are available. Refer to the Gasket Selection Chart (see page 0.5.1) and contact ROBAR for pricing and delivery.

- Please contact ROBAR with your special requirements to determine availability, price and delivery.



These products are tested and certified by WQA to NSF/ANSI standard 61

ROBAR INDUSTRIES LTD.

Surrey, British Columbia
Phone: 1-800-663-6553

Boucherville, Quebec
Phone: 1-800-315-9525

Calhoun, Georgia
Phone: 1-706-624-4404

Website: www.robarindustries.com / E-mail: waterworks@robarindustries.com



2616

FABRICATED STAINLESS STEEL SERVICE SADDLE - SERIES 2606

2616 SERVICE SADDLE CHART

NOMI- NAL PIPE SIZE	OUTLET SIZES AWWA (CC) OR IRON PIPE (IP)	BOLT STYLE DOUBLE (DB)	SADDLE WIDTH	APPROXIMATE SHIPPING WEIGHT		WORKING RANGE		
				LBS.	KG.	PIPE		
						LOW	OD	HIGH*
2	3/4 - 1 1/4**	DB	6.0	1.5	0.7	2.30	2.38	2.50
						2.50		2.70
2.5	3/4 - 1 1/2**	DB	6.0	1.8	0.8	2.70	2.88	2.90
						2.90		3.15
						3.15		3.40
3**	3/4 - 2**	DB	6.0	2.0	0.9	3.40	3.50	3.80
						3.65		3.90
						3.90		4.10
4	3/4 - 1	DB	6.0	3.3	1.5	4.00	4.50	4.40
						4.40		4.80
	1 1/4 - 2		4.80	4.80	5.20			
			5.20		5.60			
			5.60		6.00			
6	3/4 - 1	DB	6.0	3.8	1.7	6.00	6.63	6.40
						6.40		6.80
	1 1/4 - 2		6.60	6.90	7.00			
			6.80		7.20			
			7.20		7.60			
8	3/4 - 1	DB	6.0	4.8	2.2	8.00	8.63	8.40
						8.40		8.80
	1 1/4 - 2		8.60	9.05	9.05			
			8.90		9.30			
			9.00		9.40			
			9.20		9.60			
10	3/4 - 1	DB	6.0	5.8	2.5	9.60	10.75	10.00
						10.00		10.40
						10.40		10.80
	1 1/4 - 2		10.70	11.10	11.10			
			10.90		11.30			
			11.10		11.50			
			11.60		12.00			
12	3/4 - 1	DB	6.0	6.8	3.0	12.00	12.75	12.40
						12.40		12.80
	1 1/4 - 2		12.75	13.20	13.20			
			13.00		13.40			
			13.10		13.50			
			13.60		14.00			

Note: * The high limit of the range is used in the ordering code.
 ** 1-1/4" IP, 1-1/2" IP and 2" IP outlets only.
 - This product can be manufactured to your specifications. For ranges and configurations other than those listed, contact ROBAR.



All dimensions are in inches.

This product is tested and certified by WQA to NSF/ANSI standard 61

ROBAR INDUSTRIES LTD.

Surrey, British Columbia
 Phone: 1-800-663-6553

Boucherville, Quebec
 Phone: 1-800-315-9525

Calhoun, Georgia
 Phone: 1-706-624-4404

Website: www.robarindustries.com / E-mail: waterworks@robarindustries.com



2626

FABRICATED STAINLESS STEEL SERVICE SADDLE - SERIES 2606

2626 SERVICE SADDLE CHART

NOMI- NAL PIPE SIZE	OUTLET SIZES** AWWA (CC) OR IRON PIPE (IP)	SADDLE WIDTH	APPROXIMATE SHIPPING WEIGHT		WORKING RANGE		
			LBS.	KG	PIPE		
					LOW	OD	HIGH*
4	3/4 - 1	6.0	3.5	1.6	4.45	4.50	5.25
					4.74	4.80	5.54
	1 1/4 - 2	8.0	4.0	1.8	5.35		6.15
					5.90		6.70
6	3/4 - 1	6.0	4.0	1.8	6.40	6.63	7.20
					6.85	6.90	7.65
	1 1/4 - 3	8.0	4.8	2.2	7.05		7.85
8	3/4 - 1	6.0	5.0	2.3	7.95	8.63	8.75
					8.40	9.05	9.20
	1 1/4 - 3	8.0	5.5	2.5	9.00		9.80
					9.30		10.10
10	3/4 - 1	6.0	6.5	3.0	10.00	10.75	10.80
					10.70	11.10	11.50
	1 1/4 - 3	8.0	7.0	3.2	11.05		11.85
					11.40		12.20
12	3/4 - 1	6.0	8.0	3.6	12.00	12.75	12.80
					12.70	13.20	13.50
					13.10		13.90
	1 1/4 - 3	8.0	8.5	3.9	13.40		14.20
					13.70	14.00	14.50
14	3/4 - 1	6.0	8.5	3.9	14.00		14.80
					14.95	15.30	15.75
	1 1/4 - 3	8.0	9.0	4.1	15.75		16.55
16	3/4 - 1	6.0	9.8	4.4	15.60	16.00	16.40
					16.40		17.20
	1 1/4 - 3	8.0	10.3	4.7	17.20	17.40	18.00
18	3/4 - 1	6.0	10.8	4.9	17.60	18.00	18.40
					18.00		18.80
					18.40		19.20
	1 1/4 - 3	8.0	11.2	5.1	18.80		19.60
					19.20	19.50	20.00

All dimensions are in inches.

- Note: * The high limit of the range is used in the ordering code.
 ** 2 1/2" and 3" IP outlets available on nominal sizes 6" and above.
 - This product can be manufactured to your specifications. For ranges and configurations other than those listed, contact ROBAR.



This product is tested and certified by WQA to NSF/ANSI standard 61

ROBAR INDUSTRIES LTD.

Surrey, British Columbia
 Phone: 1-800-663-6553

Boucherville, Quebec
 Phone: 1-800-315-9525

Calhoun, Georgia
 Phone: 1-706-624-4404

Website: www.robarindustries.com / E-mail: waterworks@robarindustries.com



2636

FABRICATED STAINLESS STEEL SERVICE SADDLE - SERIES 2606

2636 SERVICE SADDLE CHART

NOMI- NAL PIPE SIZE	OUTLET SIZES AWWA (CC) OR IRON PIPE (IP)	SADDLE WIDTH	APPROXIMATE SHIPPING WEIGHT DOUBLE BOLT		WORKING RANGE		
			LBS.	KG.	PIPE		
					LOW	OD	HIGH*
16	3/4 - 1	6	10.8	4.9	15.92	16.00	17.12
	1 1/4 - 3	8	11.3	5.1	16.25		17.45
18	3/4 - 1	6	11.8	5.4	17.10	17.40	18.30
	1 1/4 - 3	8	12.2	5.5	17.50	18.00	18.70
20	3/4 - 1	6	12.8	5.8	19.20	19.50	20.40
	1 1/4 - 3	8	13.2	6.0	21.40	21.60	22.60
24	3/4 - 1	6	12.8	5.8	22.80		24.00
	1 1/4 - 3	8	13.2	6.0	23.45	24.00	24.65
26-30	3/4 - 1	6	13.2	6.0	24.45		25.65
	1 1/4 - 3	8	14.0	6.35	25.50	25.80	26.70
					28.25		29.45
					29.40	30.00	30.60

For larger nominal pipe sizes see 6626 outlet sleeve. (page 6.3.1)

All dimensions are in inches.

Note: 26-30": Maximum 50 PSI WP

Note: * The high limit of the range is used in the ordering code.
 - This product can be manufactured to your specifications. For ranges and configurations other than those listed, contact ROBAR.



This product is tested and certified by WQA to NSF/ANSI standard 61

ROBAR INDUSTRIES LTD.

Surrey, British Columbia
 Phone: 1-800-663-6553

Boucherville, Quebec
 Phone: 1-800-315-9525

Calhoun, Georgia
 Phone: 1-706-624-4404

Website: www.robarindustries.com / E-mail: waterworks@robarindustries.com



2706

CAST BRONZE SERVICE SADDLE



APPLICATIONS:

ROBAR 2706 Service Saddles are used to take a service outlet off a transmission or distribution line. Waterworks Bronze and passivated T304 Stainless Steel are “noble” materials which are closely related to each other near the top of the Galvanic Scale of corrosion resistance. Unlike pairs of widely dissimilar metals, they will both exhibit long life in most ‘hot’ soil environments. Can be used on PVC-C900, Ductile, Iron, Steel, HDPE and AC pipe.

MATERIAL SPECIFICATIONS:

Saddle Body: Cast Bronze.
Gasket: SBR (Buna S) Rubber.
Saddle Straps: T304 Stainless Steel, rolled threads, fully passivated*.
Fasteners: 1/2" NC T304 Stainless Steel.
Nuts coated with anti-galling compound.
Torque is 45 ft. lbs.

HOW TO ORDER:

Determine the product number (2706), the actual OD (see Table on page 2.4.2), outlet size, outlet thread, and strap style, and order by using appropriate ordering code as shown in the following example:

If a 6" Double strap (DS) Saddle with a 3/4" CC tap is required for a 6" Ductile Iron pipe (6.90" OD), the ordering code is:

2706 - 7.45" x 3/4" - CC - DS
product high outlet outlet strap style
number end size thread

i.e. 2706 - 7.45 x 3/4 - CC - DS

If a 12" Double strap (DS) Saddle with a 2" IP tap is required for a 12" C900 PVC pipe (13.20" OD), the ordering code is:

2706 - 13.30" x 2" - IP - DS
product high outlet outlet strap
number end size thread style

i.e. 2706 - 13.30 x 2 - IP - DS

Note: Some saddles have more than one strap size available. Please specify what range you require by stating the high end (H=___) as shown in the above example.

Note: * Refers to chemically treating Stainless Steel after welding ("Pickled/Passivated") to return it to its original appearance.



This product is tested and certified by WQA to NSF/ANSI standard 61

ROBAR INDUSTRIES LTD.

Surrey, British Columbia
Phone: 1-800-663-6553

Boucherville, Quebec
Phone: 1-800-315-9525

Calhoun, Georgia
Phone: 1-706-624-4404

Website: www.robarindustries.com / E-mail: waterworks@robarindustries.com



2706

CAST BRONZE SERVICE SADDLE

ROBAR 2706 Service Saddles are strong and resist corrosion. They fit pipes from Standard Steel size to Rough Barrel Asbestos Cement size. Flexible straps adapt readily to the pipe, evenly distributing load and easing installation.

2706 SERVICE SADDLE CHART							
NOMI- NAL PIPE SIZE	WORKING RANGE		OUTLET SIZES AWWA (CC) OR IRON PIPE (IP)	STRAP STYLE		APPROXIMATE SHIPPING WEIGHT	
	LOW	HIGH*		SINGLE (SS)	DOUBLE (DS)	LBS.	KG.
4	4.50	4.80	3/4 - 1	SS		2.0	0.9
			1 1/4 - 2			3.0	1.2
			3/4 - 2	DS	3.5	1.6	
6	6.60 7.10	7.45 7.60	3/4 - 1	SS		2.8	1.3
			1 1/4 - 2			3.3	1.5
			3/4 - 2	DS	6.3	2.9	
8	8.60	9.80	3/4 - 1	SS		3.3	1.5
			3/4 - 2	DS	6.5	3.0	
10	10.70	11.20	3/4 - 2		DS	7.3	3.3
	11.10	12.30					
12	12.70	13.30	3/4 - 2		DS	8.8	4.0
	13.10	14.55					
14	15.10	15.70	3/4 - 2		DS	8.8	4.0
	15.20	16.85					
16	17.20	18.00	3/4 - 2		DS	9.3	4.2
	17.40	19.00					
18-20	18.60	20.40	3/4 - 2		DS	11.4	5.1
	19.50	21.30					
	19.70	21.50					
	21.00	22.80					
24	24.60	25.60	3/4 - 2		DS	14.0	6.1
	25.65	26.50					
	26.55	27.55					
	27.60	28.55					
	29.60	30.50					

All dimensions are in inches.

- Note:
- * The high limit of the range is used in the ordering code.
 - Recommended torque: 45 ft. lbs. (Except for 24 - 60 ft. lbs.)
 - Saddles complete with flat washers.
 - Alternative gasket materials are available. Refer to the Gasket Selection Chart (see page 0.5.1) and contact ROBAR for pricing and delivery.



This product is tested and certified by WQA to NSF/ANSI standard 61

ROBAR INDUSTRIES LTD.

Surrey, British Columbia
Phone: 1-800-663-6553

Boucherville, Quebec
Phone: 1-800-315-9525

Calhoun, Georgia
Phone: 1-706-624-4404

Website: www.robarindustries.com / E-mail: waterworks@robarindustries.com



2786

CAST BRONZE ISOLATING SADDLE



APPLICATIONS:

ROBAR **2786** Isolating Saddles are used to electrically isolate an outlet or service line from a main distribution line. Primarily used in cathodically protected systems or to separate dissimilar metals. Waterworks Bronze and passivated T304 Stainless Steel are “noble” materials which are closely related to each other near the top of the Galvanic Scale of corrosion resistance. Unlike pairs of widely dissimilar metals, they will both exhibit long life in most ‘hot’ soil environments.

MATERIAL SPECIFICATIONS:

Saddle Body: Cast Bronze.
 Gaskets: SBR (Buna S) Rubber. Body and Strap.
 Strap & Armor: T304 Stainless Steel, fully passivated*.
 Fasteners: 1/2" NC T304 Stainless Steel.
 Rolled threads.
 Nuts coated with anti-galling compound.
 Torque is 45 ft. lbs.

HOW TO ORDER:

Determine the product number (**2786**), the actual OD, outlet size and outlet thread, and then use the appropriate ordering code as shown in the following example.

If an Isolating Saddle with a 3/4" CC outlet is required for 6" Standard Ductile pipe (6.90" OD) the ordering code is:

2786 - 6.90" x 3/4" - CC
 product OD (Actual) outlet outlet
 number size thread

i.e. **2786 - 6.90 x 3/4 - CC**

ELECTRICAL SPECIFICATIONS:

Conditions: Laboratory, torque level 45 ft. lbs.
 Resistance: 800 Mega ohms @ 10,000 volts DC.
 Breakdown Voltage: Minimum 12,000 volts DC.

2786 ISOLATING SADDLE CHART

NOMI- NAL PIPE SIZE	WORKING RANGE		APPROXIMATE SHIPPING WEIGHT	
	LOW	HIGH	LBS.	KG.
4	4.50	5.30	6.7	2.3
6	6.60	7.40	7.2	3.2
8	8.60	9.40	7.5	3.4
10	10.70	11.50	8.0	3.6
12	12.70	13.50	9.2	4.2
14	13.80	15.70	10.2	4.6
	15.20	16.00	10.5	4.8
16	17.20	18.00	11.0	5.0
18	19.00	20.00	11.5	5.2
20	20.80	21.90	12.0	5.4

All dimensions are in inches.

Note: * Refers to chemically treating Stainless Steel after welding (“Pickled/Passivated”) to return it to its original appearance.
 - The **2786** is designed to be installed with a maximum torque of 45 ft. lbs. This enables the saddle to perform to its maximum electrical isolating capability.

ROBAR INDUSTRIES LTD.

Surrey, British Columbia
 Phone: 1-800-663-6553

Boucherville, Quebec
 Phone: 1-800-315-9525

Calhoun, Georgia
 Phone: 1-706-624-4404

Website: www.robarindustries.com / E-mail: waterworks@robarindustries.com



2996

CONCRETE CYLINDER SERVICE SADDLE



APPLICATIONS:

The ROBAR **2996** Service Saddles are designed for making 3/4"-2" IP or CC taps into concrete steel cylinder pipe. The saddle is available from 16" through 36". Larger sizes available upon request. A grout opening is provided on the saddle body for restoring the concrete after the tap is complete.

MATERIAL SPECIFICATIONS:

Top Plate: ASTM A36.
 Outlet: Cast Ductile Iron.
 Strap: T-304L Stainless Steel, fully passivated.
 Optional carbon steel full width back strap.
 Fasteners: 5/8" NC T-304L Stainless Steel studs, rolled threads, nuts coated.
 Coating: Corrosion Protective Epoxy per AWWA C213

HOW TO ORDER:

Determine the actual outside diameter of the concrete and the steel cylinder. Determine outlet size, outlet thread and order by using appropriate ordering code as shown in the following example.

For a 24" nominal concrete cylinder pipe OD made to AWWA C301 dimension with a 2" IP tap, the ordering code is:

2996	-	24"	x	2"	-	29.00"	x	27.00"
product		OD (Nominal)		IP		CONC		Cylinder
number						OD		OD

i.e. **2996 - 24 x 2 IP**
Conc OD= 29.00"
Cylinder OD= 27.00"

Note: Outside diameter of concrete and cylinder are required at time of order.

ROBAR INDUSTRIES LTD.

Surrey, British Columbia
Phone: 1-800-663-6553

Boucherville, Quebec
Phone: 1-800-315-9525

Calhoun, Georgia
Phone: 1-706-624-4404

Website: www.robarindustries.com / E-mail: waterworks@robarindustries.com



SECTION 3 SEWER SADDLES



3606

Page 3.1.1



3626

3696

Page 3.1.1



3406

3506

Page 3.2.1

ROBAR INDUSTRIES LTD.

Surrey, British Columbia
Phone: 1-800-663-6553

Boucherville, Quebec
Phone: 1-800-315-9525

Calhoun, Georgia
Phone: 1-706-624-4404

Website: www.robarindustries.com / E-mail: waterworks@robarindustries.com



3606

STAINLESS STEEL SEWER SADDLE

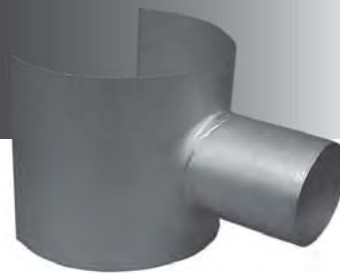

APPLICATIONS:

ROBAR **3606** Sewer Saddles are used to make a 4" inlet branch to a gravity main sewer line (4" - 4.50" OD is standard). Particularly suited for High Density Polyethylene pipe. Strapping material is not included with product.

MATERIAL SPECIFICATIONS:

Body: T304 Stainless Steel, fully passivated*.
Gaskets: 7.5" x 7.5" x .5" Neoprene.
Fasteners: Not included.

HOW TO ORDER:

Determine the product number (**3606**), the OD of sewer main and the actual OD of the branch, then order by using the appropriate ordering code as shown in the following example.

If a 4" branch (4.50" OD) off of a 12" HDPE sewer main is required, the ordering code is:

3606 - 12.75" x 4.50" i.e. **3606 - 12.75 x 4.50**
product main OD branch OD
number

Note: * Refers to chemically treating Stainless Steel after welding ("Pickled/Passivated") to return it to its original appearance.
- Standard branch outlet is 4" nominal (4.63" OD) accepts 4.50" OD.
- Special designs, lengths or diameters may be obtained from the factory on request.



3626 / 3696

STAINLESS STEEL SEWER SADDLE

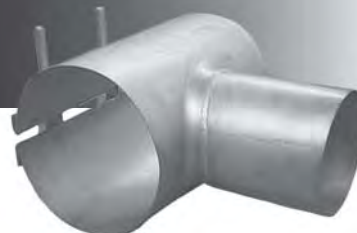

APPLICATIONS:

ROBAR **3626 / 3696** Sewer Saddles are used to make a 4" inlet branch to a main sewer line (4" - 4.50" OD is standard). Particularly suited for High Density Polyethylene pipe.

MATERIAL SPECIFICATIONS:

Body: T304 Stainless Steel, fully passivated*.
Gaskets: 7.5" x 7.5" x .5" Neoprene.
Fasteners: 1/2" NC T304 Stainless Steel Studs and washers.
Nuts coated with anti-galling compound.
Torque is 45 ft. lbs.

HOW TO ORDER:

Determine the product number (**3626, etc.**), the OD of sewer main and the actual OD of the branch, then order by using the appropriate ordering code as shown in the following example.

If a 4" branch (4.50" OD) off of a 12" HDPE sewer main is required, the ordering code is:

3626 - 12.75" x 4.50" i.e. **3626 - 12.75 x 4.50**
product main OD branch OD
number

3626 - Outlet is opposite to closure.
3696 - Outlet is 90° to closure.

Note: * Refers to chemically treating Stainless Steel after welding ("Pickled/Passivated") to return it to its original appearance.
- Standard branch outlet is 4" nominal (4.63" OD) accepts 4.50" OD.
- Special designs, lengths or diameters may be obtained from the factory on request.

ROBAR INDUSTRIES LTD.

Surrey, British Columbia
Phone: 1-800-663-6553

Boucherville, Quebec
Phone: 1-800-315-9525

Calhoun, Georgia
Phone: 1-706-624-4404

Website: www.robarindustries.com / E-mail: waterworks@robarindustries.com



3406/3506 SEWER SADDLE



APPLICATIONS:

The ROBAR Sewer Saddle allows a 4" or 6" Inlet branch to be taken off the main sewer line at a 45 degree angle. Available 6" thru 48" nominal sizes.

MATERIAL SPECIFICATIONS:

Body: Ductile Iron.
 Cast Strap: 1 1/2" wide T-304 Stainless Steel, 24 gauge. Fully passivated.
 Bolts & Nuts: T-304 Stainless Steel. Nuts coated with anti-galling compound.
 Gasket: SBR (Buna S).
 Coating: 3406 – Two coats of enamel.
 3506 – Corrosion Protective epoxy coated.

HOW TO ORDER:

Determine the product number (3406), the OD of sewer main and the actual OD of the branch, then order by using the appropriate ordering code as shown in the following example.

f a 4" branch (4.50" OD) off of a 12" HDPE sewer main is required, the ordering code is:

3406 - 12.75" x 4.50" i.e. **3406 - 12.75 x 4.50**
 product main OD branch OD
 number

MAIN SIZE (ACTUAL PIPE OD)	BRANCE SIZE (ACTUAL PIPE OD)	RUBBER BOOT SIZE (MARKINGS)	CAST BODY	STRAP LENGTH
6"–10" (6.27"– 12.75")	4" SDR 35 (4.215")	6"– 12"	WINGED BODY (4L)	36"
	4" IPS (4.5")			
12" (12.75"– 14.40")	4" SDR 35 (4.215")	6"– 12"	STANDARD BODY (4")	48"
	4" IPS (4.5")			
14"– 12" (14.40"– 25.80")	4" SDR 35 (4.215")	14"– 48"	STANDARD BODY (4")	96"
	4" IPS (4.5")			
24"– 48" (25.80"– 54.00")	4" SDR 35 (4.215")	14"– 48"	STANDARD BODY (4")	192"
	4" IPS (4.5")			

CASTING: CAST DUCTILE IRON PER ASTM A536

SADDLE BODY: SBR (BUNA S) PER ASTM D2000. FORMULATED WITH ANTI-FREEZING AND ANTI-OZONE AGENT

STRAP: T-304 STAINLESS STEEL, FULLY PASSIVATED. ADJUSTABLE TO ACCOMMODATE A LARGE RANGE OF PIPE SIZES

COATING: TWO COATS OF ENAMEL OR FUSION BONDED EPOXY

STAINLESS STEEL HOSE CLAMP GROOVE

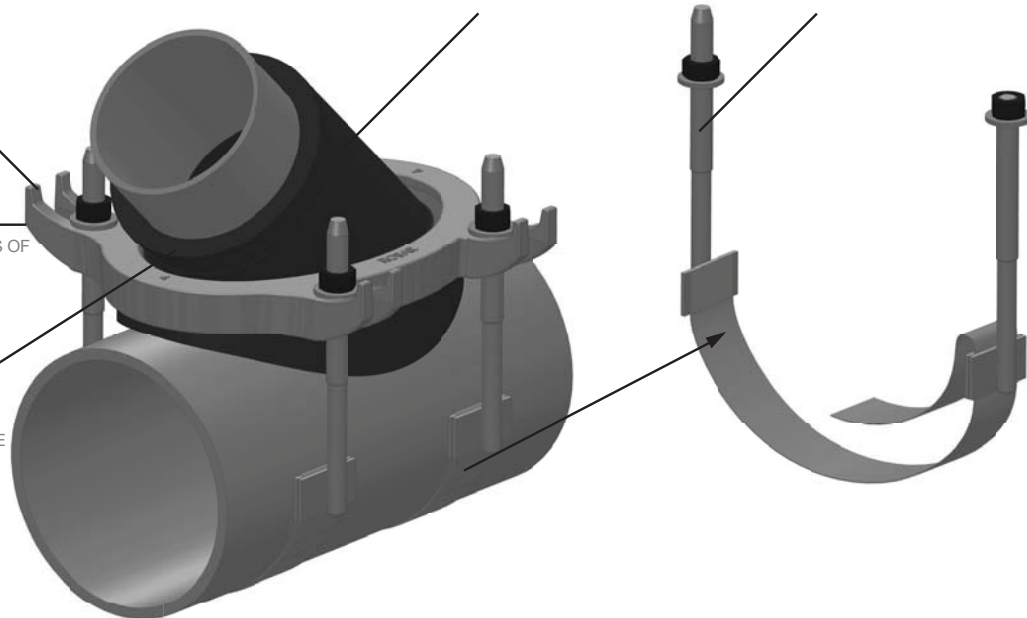

Note: - Maximum 15 PSI working pressure

ROBAR INDUSTRIES LTD.

Surrey, British Columbia
 Phone: 1-800-663-6553

Boucherville, Quebec
 Phone: 1-800-315-9525

Calhoun, Georgia
 Phone: 1-706-624-4404

Website: www.robarindustries.com / E-mail: waterworks@robarindustries.com



SECTION 4 RESTRAINERS



4499

Page 4.1.1



**M-11
HARNESS**

Page 4.2.1



4800

4900

Page 4.2.1

ROBAR INDUSTRIES LTD.

Surrey, British Columbia
Phone: 1-800-663-6553

Boucherville, Quebec
Phone: 1-800-315-9525

Calhoun, Georgia
Phone: 1-706-624-4404

Website: www.robarindustries.com / E-mail: waterworks@robarindustries.com



4499

CAST DUCTILE IRON RESTRAINT LUG



APPLICATIONS:

ROBAR 4499 Restraint Lugs are designed for use on Mechanical Joint Fittings to prevent pull-out.

MATERIAL SPECIFICATIONS:

Cast Ductile Iron with Shop Coat Enamel.

HOW TO ORDER:

Specify ROBAR Product Number (4499).

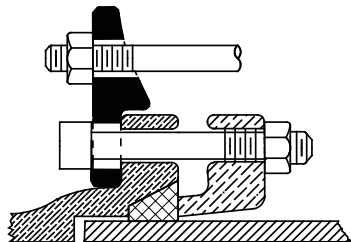

SDR 26 INSTALLATION

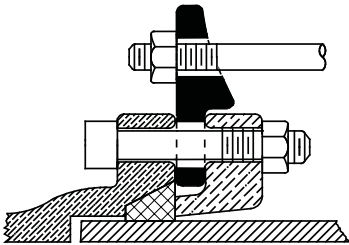

C900 OR DR 18 INSTALLATION

ROBAR INDUSTRIES LTD.

Surrey, British Columbia
Phone: 1-800-663-6553

Boucherville, Quebec
Phone: 1-800-315-9525

Calhoun, Georgia
Phone: 1-706-624-4404

Website: www.robarindustries.com / E-mail: waterworks@robarindustries.com



M-11 Harness

FOR STEEL PIPE

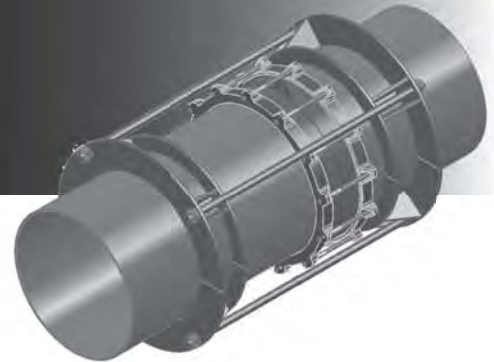

APPLICATIONS:

Joint Harness specified per AWWA M-11 are designed to restrain flexible couplings on steel pipelines. The harnesses will be supplied bare steel to allow for field welding into place. Sizes available 6" – 96". Larger sizes available on request.

MATERIAL SPECIFICATIONS:

Restraint Rings: Carbon Steel per ASTM A193 grade B7.
 Tie Rods: ASTM A193 grade B7.
 Stainless steel available on request.
 (Twice as many rods required)
 Coating: Bare, shop blasted.
 Pressure: Design pressures from 50 PSI - 250 PSI.
 Detailed in the AWWA M-11 manual.

INFORMATION REQUIRED FOR ORDERING:

- 1- Total quantity.
- 2- Steel pipe outside diameter + wall thickness.
- 3- Maximum working and test pressure.
- 4- Type of tie rods (ss or ms), if required.
- 5- Complete harness (used to restrain steel pipe x steel pipe) or half harness (used in a transition application on steel pipe).



4800 / 4900

TRIANGLE RESTRAINT LUG



APPLICATIONS:

The Robar Restraint Lug is designed to provide clearance over flanges to allow restraint rods to clear the flange and tie back to another location. The radius of the restraint lugs are to allow compatibility with AWWA C207 cls D or E flanges or ANSI B16.1 class 125 and ANSI B16.5 class 150 Flanges.

MATERIAL SPECIFICATIONS:

Lug Material: ASTM A36 Steel. T-304L or T-316L available on request.
 Tie Rod Material: ASTM A193 Gr B7 (low alloy). B8 (304SS) or B8M (316SS) available on request.
 Twice as many tie rods required when using stainless steel rods.
 Coating: 4800-Two coats Enamel or bare.
 4900-Fusion Bonded epoxy coated per AWWA C-213.

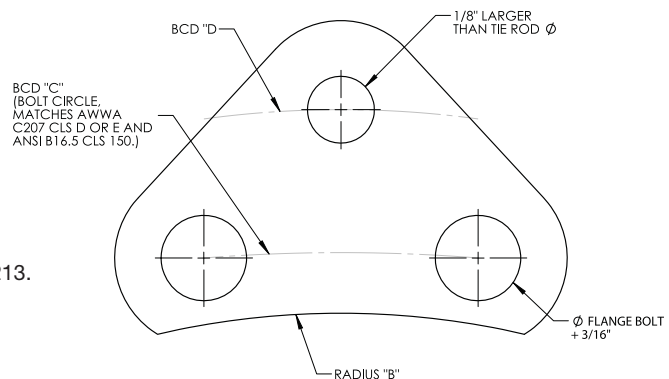

Note: 4 Nuts required per tie rod (double nut configuration).
 Tie Rods sold separately, please specify length when ordering.
 Contact Robar for quantity of lugs required for your application.

ROBAR INDUSTRIES LTD.

Surrey, British Columbia
 Phone: 1-800-663-6553

Boucherville, Quebec
 Phone: 1-800-315-9525

Calhoun, Georgia
 Phone: 1-706-624-4404

Website: www.robarindustries.com / E-mail: waterworks@robarindustries.com



SECTION 5 REPAIR CLAMPS

“The Original Stainless Steel Repair Clamp”



5616

Page 5.1.1



5626

Page 5.1.1



5636

Page 5.1.1



5606

Page 5.2.1

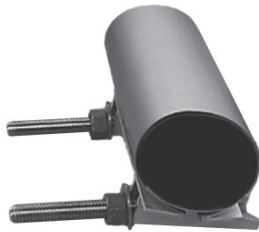

5696

Page 5.3.1



5696SC

Page 5.4.1



5518

Page 5.5.1



5528

Page 5.5.1



5538

Page 5.5.1



5508

Page 5.6.1

ROBAR INDUSTRIES LTD.

Surrey, British Columbia
Phone: 1-800-663-6553

Boucherville, Quebec
Phone: 1-800-315-9525

Calhoun, Georgia
Phone: 1-706-624-4404

Website: www.robarindustries.com / E-mail: waterworks@robarindustries.com



5616 / 5626 / 5636

STAINLESS STEEL REPAIR CLAMP - 5600 SERIES

APPLICATIONS:

ROBAR 5600 Series Repair Clamps are used to effectively repair holes or breaks in water mains.

MATERIAL SPECIFICATIONS:

Shell: T304 Stainless Steel, fully passivated*.
 Sidebar: T304 Stainless Steel, fully passivated*.
 Armor: T304 Stainless Steel, fully passivated*.
 Gasket: SBR (Buna S) Rubber.
 Fasteners: 5/8" NC T304 Stainless steel.
 Nuts coated with anti-galling compound.
 Torque is 70-80 ft. lbs.

OPTIONS:

- Outlet taps: 3/4" to 2" IP or 3/4" to 2" CC.
- Other steel and rubber material specifications.
- Multiple sections other than those specified below.



5616 (Style 1)

- 1 Section sizes 3" - 12".



5626 (Style 2)

- 2 Sections sizes 4" - 16".



5636 (Style 3)

- 3 Sections sizes 12" - 30".

HOW TO ORDER:

Determine the product number (5616, 5626, 5636), high limit number (see pages 5.1.2, 5.1.3 and 5.1.4), length of clamp and outlet size if any and then order by using the appropriate ordering code as shown in the following example.

For a one section (**Style 1**) clamp, 8" long, for a pipe with an OD of between (6.85" - 7.25"), the ordering code is:

5616	-	7.25"	x	8"
product		high limit of		clamp
number		range		width

i.e. **5616 - 7.25 x 8**

As above but with a 3/4" cc outlet: **5616 - 7.25 - 8 x 3/4 CC**

For a two section (**Style 2**) clamp, 12" long, for a pipe with an OD of between (7.05" - 7.85"), the ordering code is:

5626	-	7.85"	x	12"
product		high limit of		clamp
number		range		width

i.e. **5626 - 7.85 x 12**

As above but with a 3/4" cc outlet: **5626 - 7.85 - 12 x 3/4 CC**

For a three section (**Style 3**) clamp, 16" long, for a pipe with an OD of between (21.40" - 22.60"), the ordering code is:

5636	-	22.60"	x	16"
product		high limit of		clamp
number		range		width

i.e. **5636 - 22.60 x 16**

As above but with a 3/4" cc outlet: **5636 - 22.60 - 16 x 3/4 CC**

ROBAR IS THE ORIGINAL DEVELOPER AND PATENT HOLDER OF THE "ALL STAINLESS REPAIR CLAMP".

ALWAYS SPECIFY "ROBAR" WHEN ORDERING REPAIR CLAMPS.

Repair Clamps are designed for pipeline repairs NOT for joining two plain end pieces of pipe.

Note: * Refers to chemically treating Stainless Steel after welding ("Pickled/Passivated") to return it to its original appearance.
 - Prices for special designs, lengths or diameters may be obtained from the factory on request.
 - If tapped outlets are required, add outlet price from price list.
 - EC Pads available upon request.

ROBAR INDUSTRIES LTD.

Surrey, British Columbia
Phone: 1-800-663-6553

Boucherville, Quebec
Phone: 1-800-315-9525

Calhoun, Georgia
Phone: 1-706-624-4404

Website: www.robarindustries.com / E-mail: waterworks@robarindustries.com



5616

STAINLESS STEEL REPAIR CLAMP - STYLE 1

5616 REPAIR CLAMP CHART

NOMI- NAL PIPE SIZE	WORKING RANGE			APPROXIMATE SHIPPING WEIGHT (LBS.)					
				LENGTH OF CLAMP (Common Sizes)					
	LOW	PIPE OD	HIGH*	6"	8"	12"	16"	20"	24"
3	3.45	3.50	3.85	5.0	7.0	9.5	12.5	17.0	20.0
	3.95		4.35						
4	4.45	4.50	4.85	5.5	7.5	10.5	13.8	18.0	21.3
	4.74		4.80						
	5.05		5.45						
	5.35		5.75						
6	5.95	6.63	6.35	6.3	8.3	12.0	15.8	20.0	24.0
	6.40		6.80						
	6.60		7.00						
	6.80	6.90	7.20						
	6.85		7.25						
	7.05		7.45						
	7.40		7.80						
8	7.95	8.63	8.35	7.0	9.3	13.0	17.0	22.0	26.5
	8.40		8.80						
	8.60		9.00						
	8.90	9.05	9.30						
	9.00		9.40						
	9.30		9.70						
10	9.75	10.75	10.15	10.3	14.3	17.8	24.0	28.5	
	10.50		10.90						
	10.70		11.10						
	11.05		11.10						11.45
	11.40								11.80
11.70		12.10							
12	12.00	12.75	12.40	12.3	16.3	21.3	28.0	33.3	
	12.55		12.95						
	12.70								13.10
	13.10		13.20						13.50
	13.40								13.80
	13.70		14.00						14.10

All dimensions are in inches.

HOW TO ORDER:

See HOW TO ORDER on page 5.1.1.

- Note:
- * The high limit of the range is used in the ordering code.
 - 3/4" - 2" IP or CC outlets are available for an additional cost.
 - Longer repair clamps are available. Please contact ROBAR for more information.

ROBAR INDUSTRIES LTD.

Surrey, British Columbia
Phone: 1-800-663-6553

Boucherville, Quebec
Phone: 1-800-315-9525

Calhoun, Georgia
Phone: 1-706-624-4404

Website: www.robarindustries.com / E-mail: waterworks@robarindustries.com



5626

STAINLESS STEEL REPAIR CLAMP - STYLE 2

5626 REPAIR CLAMP CHART

NOMI- NAL PIPE SIZE	WORKING RANGE			APPROXIMATE SHIPPING WEIGHT (LBS.)				
				LENGTH OF CLAMP (Common Sizes)				
	LOW	PIPE OD	HIGH*	8"	12"	16"	20"	24"
4	4.45	4.50	5.25	10.8	16.0	21.0	27.0	32.3
	4.74	4.80	5.54					
	5.35		6.15					
	5.90		6.70					
6	6.40	6.63	7.20	11.3	17.0	21.5	29.0	34.5
	6.85	6.90	7.65					
	7.05		7.85					
8	7.95	8.63	8.75	12.5	18.3	23.5	31.0	36.8
	8.40	9.05	9.20					
	9.00		9.80					
	9.30		10.10					
10	10.00	10.75	10.80	13.8	19.3	25.0	33.0	38.5
	10.70	11.10	11.50					
	11.05		11.85					
	11.40		12.20					
12	12.00	12.75	12.80	15.8	23.5	28.3	39.0	45.0
	12.70	13.20	13.50					
	13.10		13.90					
	13.40		14.20					
14	13.70	14.00	14.50	16.5	24.5	29.8	41.0	48.8
	14.00		14.80					
	14.95	15.30	15.75					
16	15.75	16.00	16.55	18.0	26.0	31.0	43.0	50.6
	17.20	17.40	18.00					

All dimensions are in inches.

HOW TO ORDER:

See HOW TO ORDER on page 5.1.1.

- Note:
- * The high limit of the range is used in the ordering code.
 - 3/4" - 2" IP or CC outlets are available for an additional cost.
 - Longer repair clamps are available. Please contact ROBAR for more information.

ROBAR INDUSTRIES LTD.

Surrey, British Columbia
Phone: 1-800-663-6553

Boucherville, Quebec
Phone: 1-800-315-9525

Calhoun, Georgia
Phone: 1-706-624-4404

Website: www.robarindustries.com / E-mail: waterworks@robarindustries.com



5636

STAINLESS STEEL REPAIR CLAMP - STYLE 3

5636 REPAIR CLAMP CHART

NOMI- NAL PIPE SIZE	WORKING RANGE			APPROXIMATE SHIPPING WEIGHT (LBS.)				
				LENGTH OF CLAMP (Common Sizes)				
	LOW	PIPE OD	HIGH*	8"	12"	16"	20"	24"
12	12.80	13.20	14.00	18.5	31.0	40.5	52.0	62.5
	13.65	14.00	14.85					
14	14.85	15.30	16.05	20.0	33.0	43.0	54.0	65.5
	15.92	16.00	17.12					
16	16.25		17.45	22.5	34.0	45.5	56.0	67.5
	17.10	17.40	18.30					
18	17.40	18.00	18.60	23.0	34.5	46.0	58.0	69.0
	19.20	19.50	20.40					
20	21.40	21.60	22.60	24.0	37.0	48.0	60.0	72.0
	22.80		24.00					
	23.45	24.00	24.65					
24	24.45		25.65	28.0	41.0	52.0	70.0	84.0
	25.50	25.80	26.70					
	28.25		29.45					
30	29.40	30.00	30.60	34.0	46.0	51.0	74.0	89.0
	29.85		31.05					
	30.85		32.05					
	31.50	32.00	32.70					

All dimensions are in inches.

HOW TO ORDER:

See HOW TO ORDER on page 5.1.1.

- Note:
- * The high limit of the range is used in the ordering code.
 - 3/4" - 2" IP or CC outlets are available for an additional cost.
 - Longer repair clamps are available. Please contact ROBAR for more information.

ROBAR INDUSTRIES LTD.

Surrey, British Columbia
Phone: 1-800-663-6553

Boucherville, Quebec
Phone: 1-800-315-9525

Calhoun, Georgia
Phone: 1-706-624-4404

Website: www.robarindustries.com / E-mail: waterworks@robarindustries.com



5606

STAINLESS STEEL REPAIR CLAMP



APPLICATIONS:

ROBAR 5606 Single Section Repair Clamps are used to repair small holes or breaks in water mains. The 5606 has a full wrap gasket.

MATERIAL SPECIFICATIONS:

Shell: T304 Stainless Steel, fully passivated*.
 Sidebar: T304 Stainless Steel, fully passivated*.
 Armor: T304 Stainless Steel, fully passivated*.
 Gasket: SBR (Buna S) Rubber.
 Fasteners: 1/2" NC T304 Stainless steel.
 Nuts coated with anti-galling compound.
 Torque is 45 ft. lbs.

HOW TO ORDER:

Determine the product number (5606), high limit of range (see table below) and length of clamp and then order by using appropriate ordering code as shown in the following example.

For a 12" long clamp on a pipe with an OD of between (6.85" - 7.10"), the ordering code is:

5606 7.10" x 12"
 product high limit of clamp
 number range width

i.e. **5606 - 7.10 x 12**

5606 REPAIR CLAMP CHART

NOMI- NAL PIPE SIZE	WORKING RANGE		APPROXIMATE SHIPPING WEIGHT (LBS.)			
			LENGTH OF CLAMP (Common Sizes)			
	LOW	HIGH	4"	6"	8"	12"
2	2.12	2.37	1.0	1.8	2.0	3.1
	2.25	2.50				
	2.37	2.62				
	2.63	2.88				
	2.87	3.12				
3	3.25	3.50	1.5	2.5	3.0	4.5
	3.50	3.75				
	3.74	3.99				
4	4.45	4.70	1.8	3.0	4.5	5.3
	4.75	5.00				
6	6.58	6.83	2.5	3.8	5.0	7.5
	6.85	7.10				
8	8.58	8.83	2.8	4.5	5.5	8.3
	9.00	9.25				

All dimensions are in inches.

Note: * Refers to chemically treating Stainless Steel after welding ("Pickled/Passivated") to return it to its original appearance.
 - Prices for special designs, lengths or diameters may be obtained from the factory on request.

ROBAR INDUSTRIES LTD.

Surrey, British Columbia
 Phone: 1-800-663-6553

Boucherville, Quebec
 Phone: 1-800-315-9525

Calhoun, Georgia
 Phone: 1-706-624-4404

Website: www.robarindustries.com / E-mail: waterworks@robarindustries.com



5696

STAINLESS STEEL REPAIR CLAMP

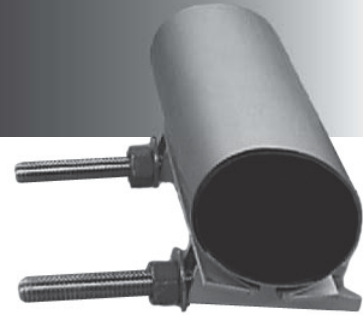

APPLICATIONS:

ROBAR 5696 Single Section Repair Clamps are used to repair small punctures, pinholes and splits which do not require the full wrap-around gasket provided by the 5606 repair clamp.

MATERIAL SPECIFICATIONS:

Shell: T304 Stainless Steel, fully passivated*.
Sidebar: T304 Stainless Steel, fully passivated*.
Gasket: SBR (Buna S) Rubber.
Fasteners: 1/2" NC T304 Stainless steel.
Nuts coated with anti-galling compound.
Torque is 45 ft. lbs.

HOW TO ORDER:

Determine the product number (5696), high limit of range (see table below) and length of clamp and then order by using appropriate ordering code as shown in the following example.

For a 12" long clamp on a pipe with an OD of between (6.63" - 6.88"), the ordering code is:

5696 - 6.88" x 12"
product high limit of clamp
number range width

i.e. **5696 - 6.88 x 12**

5696 REPAIR CLAMP CHART

NOMI- NAL PIPE SIZE	WORKING RANGE		APPROXIMATE SHIPPING WEIGHT (LBS.)			
			LENGTH OF CLAMP (Common Sizes)			
	LOW	HIGH	4"	6"	8"	12"
2	1.90	2.15	1.0	1.8	2.0	3.1
	2.00	2.25				
	2.25	2.50				
	2.37	2.62				
	2.87	3.12				
3	3.12	3.37	1.3	2.0	2.5	3.8
	3.50	3.75				
4	4.12	4.37	1.5	2.5	3.0	4.5
	4.50	4.75				
6	6.12	6.37	2.0	3.3	4.0	6.0
	6.63	6.88				
8	8.63	8.88	2.5	3.8	5.0	7.5

All dimensions are in inches.

Note: * Refers to chemically treating Stainless Steel after welding ("Pickled/Passivated") to return it to its original appearance.
- Prices for special designs, lengths or diameters may be obtained from the factory on request.

ROBAR INDUSTRIES LTD.

Surrey, British Columbia
Phone: 1-800-663-6553

Boucherville, Quebec
Phone: 1-800-315-9525

Calhoun, Georgia
Phone: 1-706-624-4404

Website: www.robarindustries.com / E-mail: waterworks@robarindustries.com



5696SC

STAINLESS STEEL SNAP CLAMP



APPLICATIONS:

ROBAR **5696SC** Single Section SNAP Clamps are used to repair small punctures, pinholes and splits which do not require a full wrap-around gasket.

MATERIAL SPECIFICATIONS:

Shell: T304 Stainless Steel
Sidebar: T304 Stainless Steel
Gasket: Nitrile Rubber (NBR)
Fasteners: T304 Stainless Steel,
Electrolytic Zinc Plated Nuts
Torque is 45ft. lbs.

HOW TO ORDER:

Determine the product number (**5696SC**), the pipe outside diameter and the length of clamp you require and then order by using the appropriate ordering code as shown in the following example.

For a 2" steel pipe diameter (2.38") and a length of 6", the ordering code is:

5696SC - 2" x 6" Snap Clamp

5696SC SNAP CLAMP CHART

NOMI- NAL PIPE SIZE	WORKING RANGE		APPROXIMATE SHIPPING WEIGHT (LBS.)		
			LENGTH OF CLAMP		
	LOW	HIGH	3"	6"	9"
1/2	0.83	0.98	1.0	2.0	3.0
3/4	1.02	1.18	1.0	2.0	3.0
1	1.30	1.46	1.0	2.0	3.0
1-1/4	1.65	1.77	1.0	2.0	3.0
1-1/2	1.89	2.01	1.0	2.5	3.5
2	2.36	2.52	1.0	2.5	4.0
2.5	2.80	2.96	1.0	2.5	4.0
3	3.43	3.66	1.5	3.0	4.5
4	4.41	4.61	1.5	3.0	4.5

All dimensions are in inches.

ROBAR INDUSTRIES LTD.

Surrey, British Columbia
Phone: 1-800-663-6553

Boucherville, Quebec
Phone: 1-800-315-9525

Calhoun, Georgia
Phone: 1-706-624-4404

Website: www.robarindustries.com / E-mail: waterworks@robarindustries.com



5518 / 5528 / 5538

REPAIR CLAMPS WITH CAST LUGS

APPLICATIONS:

The ROBAR 5500 Series Repair Clamps with cast lugs are used to effectively repair holes or breaks in water mains.

MATERIAL SPECIFICATIONS:

Shell: T304 Stainless Steel.
Lugs: Ductile Iron, epoxy coated.
Armor: T304 Stainless Steel.
Gasket: NBR (Buna N) Rubber.
Fasteners: 5/8 HSLA bolts and nuts.
Stainless steel option.

OPTIONS:

- Outlet taps: 3/4" to 2" IP or 3/4" to 2" CC.
- Other steel and rubber material specifications.
- Multiple sections other than those specified below.



5518 (Style 1)

- 1 Section sizes 3" - 12".



5528 (Style 2)

- 2 Sections sizes 4" - 16".



5538 (Style 3)

- 3 Sections sizes 12" - 30".

HOW TO ORDER

Determine the product number (5518 / 5528 / 5538), high limit number (see pages 5.1.2, 5.1.3 and 5.1.4), length of clamp and outlet size if any and then order by using the appropriate ordering code as shown in the following example.

For a one section (Style 1) clamp, 8" long, for a pipe with an OD of between (6.85" - 7.25"), the ordering code is:

5518	-	7.25"	x	8"
product		high limit		clamp
number		of range		width

i.e. 5518 - 7.25 x 8

As above but with a 3/4" cc outlet **5518 - 7.25 - 8 x 3/4 CC**

For a two section (Style 2) clamp, 12" long, for a pipe with an OD of between (7.05" - 7.85"), the ordering code is:

5528	-	7.85"	x	12"
product		high limit		clamp
number		of range		width

i.e. 5528 - 7.25 x 8

As above but with a 3/4" cc outlet **5528 - 7.85 - 12 x 3/4 CC**

For a three section (Style 3) clamp, 16" long, for a pipe with an OD of between (21.40" - 22.60"), the ordering code is:

5538	-	22.60"	x	16"
product		high limit		clamp
number		of range		width

i.e. 5538 - 22.60 x 16

As above but with a 3/4" cc outlet **5538 - 22.60 - 16 x 3/4 CC**

- Note:
- Prices for special designs, lengths or diameters may be obtained from the factory on request.
 - If tapped outlets are required, add outlet price from price list.
 - EC Pads available upon request.

ROBAR INDUSTRIES LTD.

Surrey, British Columbia
Phone: 1-800-663-6553

Boucherville, Quebec
Phone: 1-800-315-9525

Calhoun, Georgia
Phone: 1-706-624-4404

Website: www.robarindustries.com / E-mail: waterworks@robarindustries.com



5508

BELL JOINT LEAK CLAMP



APPLICATIONS:

ROBAR 5508 Bell joint leak clamp
Used to repair leaking Ductile Iron & Cast Iron Bell joints.

MATERIAL SPECIFICATIONS:

Body Casting: Ductile Iron per ASTM A536
Gasket: NBR
Coating: Epoxy coated
Bolts & Nuts: Low alloy Steel per ASTM A325 and A563

HOW TO ORDER:

Determine the product number (5508, etc.), and order the nominal size you require and then use the appropriate ordering code as shown in the example.

For 8" Ductile Iron pipe (9.05" OD), the ordering code is:

5508 - 8"
product nom.main
number size

i.e. 5508 - 8

Nominal Pipe Size	WEIGHT		Working Range
	LBS	KG	
4"	25	11	4.80" - 5.00"
6"	32	15	6.90" - 7.10"
8"	37	17	9.05" - 9.30"
10"	45	20	11.10" - 11.40"
12"	69	31	13.20" - 13.50"
16"	103	47	17.40" - 17.80"
24"	157	71	25.80" - 26.32"

Note: Contact Robar for sizes larger than 24"

ROBAR INDUSTRIES LTD.

Surrey, British Columbia
Phone: 1-800-663-6553

Boucherville, Quebec
Phone: 1-800-315-9525

Calhoun, Georgia
Phone: 1-706-624-4404

Website: www.robarindustries.com / E-mail: waterworks@robarindustries.com



SECTION 6 TAPPING SLEEVES



6404
6506

Page 6.1.1



6606
6606BB

Page 6.2.1



6626

Page 6.3.1



6636AS

Page 6.4.1



6808
6906

Page 6.5.1



6828
6926

Page 6.6.1



6898
6996

Page 6.7.1

ROBAR INDUSTRIES LTD.

Surrey, British Columbia
Phone: 1-800-663-6553

Boucherville, Quebec
Phone: 1-800-315-9525

Calhoun, Georgia
Phone: 1-706-624-4404

Website: www.robarindustries.com / E-mail: waterworks@robarindustries.com



6404 / 6506

CAST DUCTILE IRON TAPPING SLEEVE



APPLICATIONS:

ROBAR 6404 / 6506 Tapping Sleeves are used to make a branch outlet off a main supply line on Ductile or Cast Iron pipe only. The outside diameters of Ductile Iron and Cast Iron are within the working range of this tapping sleeve.

MATERIAL SPECIFICATIONS:

Body: Cast Ductile Iron.
 Flange: Cast Ductile Iron, 150 lb. Drilling.
 Gaskets: NBR (Buna N) Rubber, c/w O-Ring.
 Fasteners: **6404** - 3/4" NC Cast Ductile bolts.
6506 - 3/4" NC T304 Stainless Steel.
 Nuts coated with anti-galling compound.
 Torque is 75-80 ft. lbs.
 Test Plug: 3/4" NPT Mild Steel.
 Coating: **6404** - Two coats of Enamel.
6506 - Corrosion Protective Epoxy coating.

HOW TO ORDER:

Determine the product number (**6404, etc.**), nominal main size, nominal outlet size and actual main OD, and then order by using the appropriate ordering code (see table below) as shown in the following example.

If an Epoxy coated Tapping sleeve with Stainless Steel fasteners is required to install a 6" outlet on an 8" Ductile Iron water pipe (9.05" OD), the ordering code is:

6506 - 8" x 6" - 9.05"
 product nom. main x nom. outlet actual main
 number size size OD

i.e. **6506 - 8 x 6 - 9.05**

NOMINAL PIPE SIZE	ORDERING CODE*	APPROXIMATE SHIPPING WEIGHT		WORKING RANGE
		LBS.	KG.	
4 x 4	PN - 4" x 4" x OD	39	17.1	4.74 - 5.10
6 x 4	PN - 6" x 4" x OD	45	20.4	6.86 - 7.10
6 x 6	PN - 6" x 6" x OD	51	23.1	6.86 - 7.10
8 x 4	PN - 8" x 4" x OD	64	29.0	8.99 - 9.30
8 x 6	PN - 8" x 6" x OD	68	30.9	8.99 - 9.30
8 x 8	PN - 8" x 8" x OD	80	36.4	8.99 - 9.30

Note: *PN stands for the Product Number (6404, etc.).

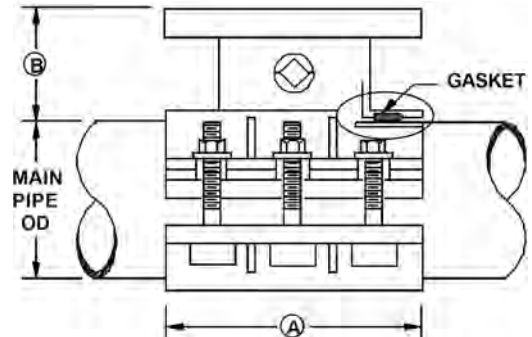

NOMINAL PIPE SIZE	OUTLET SIZE	A SLEEVE LENGTH	B FLANGE HEIGHT	C SPIGOT OD	D BRANCH ID	NUMBER OF BOLTS	BOLT SIZE
4	4	8	3 5/8	5 1/32	4 3/8	6	3/4
6	4	8 1/2	3 5/8	5 1/32	4 3/8	6	3/4
	6	8 1/2	3 5/8	7 1/32	6 3/8	6	3/4
8	4	9 1/2	3 3/4	5 1/32	4 3/8	6	3/4
	6	9 1/2	3 3/4	7 1/32	6 3/8	6	3/4
	8	9 1/2	3 3/4	9 1/32	8 3/8	6	3/4

All dimensions are in inches.

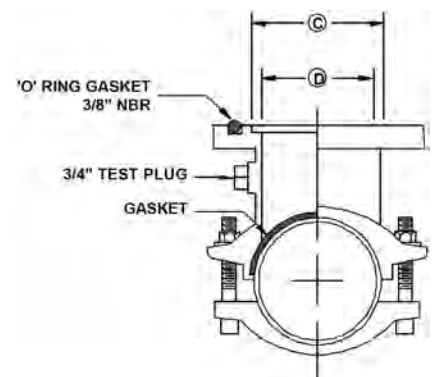

Note: - Not recommended for use on Plastic pipe (PVC or HDPE) or Asbestos Cement pipe.

ROBAR INDUSTRIES LTD.

Surrey, British Columbia
 Phone: 1-800-663-6553

Boucherville, Quebec
 Phone: 1-800-315-9525

Calhoun, Georgia
 Phone: 1-706-624-4404

Website: www.robarindustries.com / E-mail: waterworks@robarindustries.com



6606 Series

STAINLESS STEEL TAPPING SLEEVE

APPLICATIONS:

The ROBAR **6606 Series Tapping Sleeves** are used for “WET” or “DRY” tapping. Available for pipe diameters from 4” to 24”. Outlet options: 4” to 12”. Larger nominal sizes and/or larger flange sizes available upon request. Not for use on Concrete Cylinder pipe.

6606 Lifter Bar

MATERIAL SPECIFICATIONS:

Shell: T-304 Stainless Steel, fully passivated*.
 Fasteners: 5/8” NC T304 Stainless Steel. Nuts coated with anti-galling compound.
 Torque is 70-80 ft. lbs.
 Gaskets: Ringseal: NBR (Buna N) Rubber. Liner: SBR (Buna S) Rubber. Full wrap around.
 Test Plug: 3/4” NPT Stainless Steel.
 Flange: T-304 Stainless Steel*, as per AWWA C-207 Class D. (Carbon Steel, Epoxy coated Flange available)
 Outlet Pipe: T-304 Stainless Steel, fully passivated*.



TAPPING SLEEVE DATA					
NOMINAL OUTLET SIZE	A	B	C (DIA.)	D (DIA.)	BOLT SIZE
3	12	4	4 1/32	3 1/2	5/8
4	12	4	5 1/32	4 1/2	5/8
6	16	4 1/2	7 1/32	6 1/2	5/8
8	20	5	9 1/32	8 1/2	5/8
10	20	5 1/2	11 1/32	10 7/16	5/8
12	24	5 3/4	13 1/32	12 7/16	5/8

All dimensions are in inches.

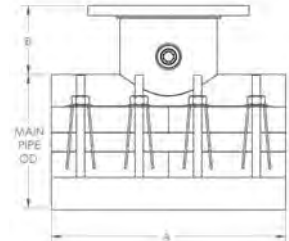
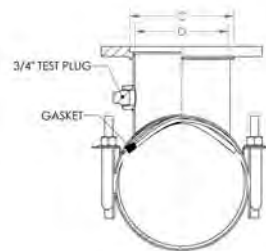

HOW TO ORDER:

Determine the product number (**6606**), nominal main size, nominal outlet size, high limit number (see table above), and then order using the appropriate ordering code as shown in the following example. If a Stainless Steel Tapping Sleeve, with a 6” nominal outlet is required for a 12” nominal diameter Ductile Iron pipe (13.20” OD), the ordering code is:

6606 - 12” x 6” - 13.40” i.e. **6606 - 12 x 6 - 13.40**
 product nom. main size nom. outlet size high end of range

6606 Tapping Sleeves come in 3 sections for nominal pipe sizes of 18” - 24”.

- 6606** – Stainless Steel fabrication with Lifter bar closure
- 6606BB** – Stainless steel fabrication with bolt bracket closures
- 6606MJ** – Stainless Steel fabrication with Lifter bar closure and MJ flange
- 6606BBMJ** – Stainless steel fabrication with bolt bracket closures and MJ flange
- 6606CSF** – Stainless Steel fabrication with Lifter bar closure and epoxy coated carbon steel flange
- 6606BBCSF** – Stainless Steel fabrication with bolt bracket closure and epoxy coated carbon steel flange

Note: - For sizes not listed above, call ROBAR for availability.
 - The working range displayed is only a guideline, other ranges are available.



This product is tested and certified by WQA to NSF/ANSI standard 61

ROBAR INDUSTRIES LTD.

Surrey, British Columbia
 Phone: 1-800-663-6553

Boucherville, Quebec
 Phone: 1-800-315-9525

Calhoun, Georgia
 Phone: 1-706-624-4404

Website: www.robarindustries.com / E-mail: waterworks@robarindustries.com



6606 Series

STAINLESS STEEL TAPPING SLEEVE

Mechanical Joint Flange

MATERIAL SPECIFICATIONS:

- Shell: T-304 Stainless Steel, fully passivated*.
- Fasteners: 5/8" NC T304 Stainless Steel. Nuts coated with anti-galling compound. Torque is 70-80 ft. lbs.
- Gaskets: Ringseal: NBR (Buna N) Rubber. Liner: SBR (Buna S) Rubber. Full wrap around.
- Test Plug: 3/4" NPT Stainless Steel.
- Flange: T-304 Stainless Steel*, as per AWWA C-111. (Carbon Steel, Epoxy coated Flange available)
- Outlet Pipe: T-304 Stainless Steel, fully passivated*.



TAPPING SLEEVE DATA				
NOMINAL OUTLET SIZE	A	B	C	BOLT SIZE
4	12	4	4 13/32	5/8
6	16	4 1/2	6 11/32	5/8
8	20	5	8 1/2	5/8
10	20	5 1/2	10 3/8	5/8
12	24	5 3/4	12 1/4	5/8

All dimensions are in inches.

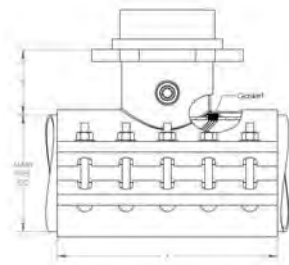
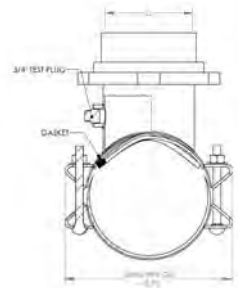

6606 Bolt Bracket

MATERIAL SPECIFICATIONS:

- Shell: T-304 Stainless Steel, fully passivated*.
- Fasteners: 5/8" NC T304 Stainless Steel. Nuts coated with anti-galling compound. Torque is 70-80 ft. lbs.
- Gaskets: Ringseal: NBR (Buna N) Rubber. Liner: SBR (Buna S) Rubber. Full wrap around.
- Test Plug: 3/4" NPT Stainless Steel.
- Flange: T-304 Stainless Steel*, as per AWWA C-207 Class D. (Carbon Steel, Epoxy coated Flange and MJ available)
- Outlet Pipe: T-304 Stainless Steel, fully passivated*.



TAPPING SLEEVE DATA					
NOMINAL OUTLET SIZE	A	B	C (DIA.)	D (DIA.)	BOLT SIZE
3	12	4	4 1/32	3 1/2	5/8
4	12	4	5 1/32	4 1/2	5/8
6	16	4 1/2	7 1/32	6 1/2	5/8
8	20	5	9 1/32	8 1/2	5/8
10	20	5 1/2	11 1/32	10 7/16	5/8
12	24	5 3/4	13 1/32	12 7/16	5/8

All dimensions are in inches.

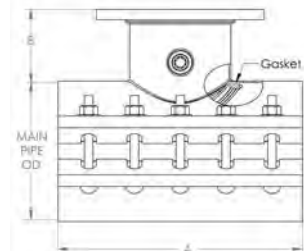
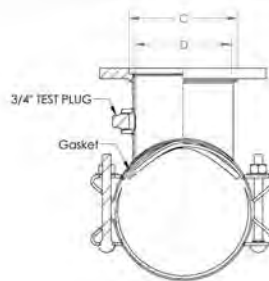

ROBAR INDUSTRIES LTD.

Surrey, British Columbia
Phone: 1-800-663-6553

Boucherville, Quebec
Phone: 1-800-315-9525

Calhoun, Georgia
Phone: 1-706-624-4404

Website: www.robarindustries.com / E-mail: waterworks@robarindustries.com



6606 Series

TAPPING SLEEVE

NOMINAL OUTLET SIZE	BY	OUTLET SIZE	FITTING LENGTH	NUMBER OF BOLTS	APPROXIMATE SHIPPING WEIGHT		LOW	HIGH
					LBS.	KG.		
4	X	3	12	8	33	15.0	4.70 4.95	4.95 5.20
		4*			36	16.4		
6	X	3	12	8	36	16.4	6.40 6.80	7.20 7.60
		4			39	17.7		
		6*	16	10	43	19.6	6.75	7.00
							6.85	7.10
					7.00	7.25		
					7.25	7.50		
8	X	3	12	8	40	18.2	8.40 8.80	8.80 9.20
		4			43	19.6		
		5	16	10	47	21.4	9.20	9.60
		8*	20	14	64	29.1	8.95 9.25	9.20 9.50
10	X	3	12	8	43	19.6	10.55 10.90 11.30 11.90	10.95 11.30 11.70 12.30
		4			46	20.9		
		6	16	10	50	22.7		
		8	20	14	68	30.9		
		10			73	33.2		
12	X	3	12	8	46	20.9	12.15 12.55 13.00 13.40 13.80	12.55 12.95 13.40 13.80 14.20
		4			49	22.3		
		6	16	10	53	24.1		
		8	20	14	72	32.7		
		10			77	35.0		
		12	24	16	111	50.5		
14	X	3	12	8	67	30.5	15.10 15.50 15.80 16.20	15.50 15.90 16.20 16.60
		4			70	31.8		
		6	16	10	74	33.6		
		8	20	14	93	42.3		
		10			98	44.6		
		12	24	16	132	60.0		
16	X	3	12	12	71	32.3	17.20 17.40 17.80 18.40 18.80	17.60 17.80 18.20 18.80 19.20
		4			75	34.1		
		6	16	15	79	35.9		
		8	20	21	100	45.5		
		10			105	47.7		
		12	24	24	141	64.1		
18	X	3	12	12	74	33.6	19.30 19.80 20.20	19.70 20.20 20.60
		4			77	35		
		6	16	15	81	36.8		
		8	20	21	103	46.8		
		10			108	49.1		
		12	24	24	144	65.5		
20	X	3	12	12	84	38.2	21.40 22.00 22.60	21.80 22.40 23.00
		4			87	39.6		
		6	16	15	91	41.4		
		8	20	21	115	52.3		
		10			120	54.6		
		12	24	24	158	71.8		
24	X	3	12	12	90	40.9	23.20 23.80 25.60	23.60 24.20 26.00
		4			93	42.3		
		6	16	15	97	44.1		
		8	20	21	121	55.0		
		10			127	57.7		
		12	24	24	167	75.9		

Note: Size on size for IPS is not available.

Note: * For size on size tapping an undersize cutter is used.

ROBAR INDUSTRIES LTD.

Surrey, British Columbia
Phone: 1-800-663-6553

Boucherville, Quebec
Phone: 1-800-315-9525

Calhoun, Georgia
Phone: 1-706-624-4404

Website: www.robarindustries.com / E-mail: waterworks@robarindustries.com



6626

STAINLESS STEEL OUTLET SLEEVE



APPLICATIONS:

ROBAR 6626 Outlet Sleeves are used for "DRY TAP" applications. Outlet options are 3" through 12" including size on size for 4" and above. Particularly suited for use on High Density Polyethylene (HDPE).

MATERIAL SPECIFICATIONS:

Shell: T-304 Stainless Steel, fully passivated.**
 Fasteners: 5/8" NC T304 Stainless Steel,
 Rolled threads. Nuts coated with anti-galling compound.
 Torque is 70-80 ft. lbs.
 Gaskets: Ringseal: NBR (Buna N) Rubber.
 Liner: SBR (Buna S) Rubber.
 Flange: T-304 Stainless Steel* as per AWWA C-207 Class D.
 Outlet: T-304 Stainless Steel*.

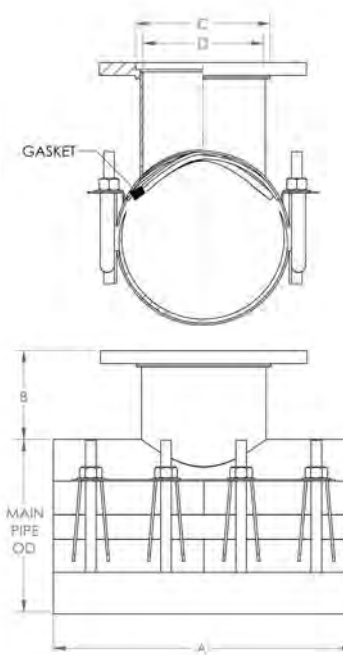

OUTLET SLEEVE DATA					
NOMINAL OUTLET SIZE	A	B	C (DIA.)	D (DIA.)	BOLT SIZE
3	12	4	3.25	3	5/8
4	12	4	4.25	4	5/8
6	16	4.5	6.25	6	5/8
8	20	5	8.25	8	5/8
10	20	5.5	10.25	10	5/8
12	24	5.75	12.25	12	5/8

All dimensions are in inches.

NOMINAL PIPE SIZE	BY X	OUTLET SIZE	FITTING LENGTH	NUMBER OF BOLTS	APPROXIMATE SHIPPING WEIGHT		WORKING RANGE	
					LBS.	KG.	LOW	HIGH
4	X	3	12	8	33	15.0	4.70	4.95
		4*			36	16.4	4.95	5.20
6	X	3	12	8	36	16.4	6.40	6.80
		4			39	17.7	6.80	7.20
		6*	16	10	43	19.6	6.75	7.00
					43	19.6	6.85	7.10
8	X	3	12	8	40	18.2	8.40	8.80
		4			43	19.6	8.80	9.20
		6	16	10	47	21.4	9.20	9.60
					64	29.1	8.95	9.20
		8*	20	14			9.25	9.50

6626 rated for 150 PSI working pressure (contact Robar for higher pressure ratings).

- Note: - Contact ROBAR for tapping into HDPE DR21 and higher.
 **Refers to chemically treating Stainless Steel after welding ("Pickled/Passivated") to return it to its original appearance.
 * Size on size for IPSOD is not available.
 - For size on size tapping an undersize cutter is used.



This product is tested and certified by WQA to NSF/ANSI standard 61

ROBAR INDUSTRIES LTD.

Surrey, British Columbia
 Phone: 1-800-663-6553

Boucherville, Quebec
 Phone: 1-800-315-9525

Calhoun, Georgia
 Phone: 1-706-624-4404

Website: www.robarindustries.com / E-mail: waterworks@robarindustries.com



6626

STAINLESS STEEL OUTLET SLEEVE

NOMINAL PIPE SIZE	BY X	OUTLET SIZE	FITTING LENGTH	NUMBER OF BOLTS	APPROXIMATE SHIPPING WEIGHT		WORKING RANGE			
					LBS.	KG.	LOW	HIGH		
10	X	3	12	8	43	19.6	10.55	10.95		
		4			46	20.9				
		6	16	10	50	22.7			11.30	11.70
		8	20	14	68	30.9			11.90	12.30
		10"			73	33.2				
12	X	3	12	8	46	20.9	12.15	12.55		
		4			49	22.3				
		6	16	10	53	24.1			13.00	13.40
		8	20	14	72	32.7			13.40	13.80
		10			77	35.0				
		12"	24	16	111	50.5			13.80	14.20
14	X	3	12	8	67	30.5	15.10	15.50		
		4			70	31.8				
		6	16	10	74	33.6			15.50	15.90
		8	20	14	93	42.3			15.80	16.20
		10			98	44.6				
		12	24	16	132	60.0			16.20	16.60
16	X	3	12	8	71	32.3	17.20	17.60		
		4			75	34.1				
		6	16	10	79	35.9			17.40	17.80
		8	20	14	100	45.5			17.80	18.20
		10			105	47.7				
		12	24	16	141	64.1			18.40	18.80
18	X	3	12	12	74	33.6	19.30	19.70		
		4			77	35				
		6	16	15	81	36.8			19.80	20.20
		8	20	21	103	46.8			20.20	20.60
		10			108	49.1				
		12	24	24	144	65.5				
20	X	3	12	12	84	38.2	21.40	21.80		
		4			87	39.6				
		6	16	15	91	41.4			22.00	22.40
		8	20	21	115	52.3			22.60	23.00
		10			120	54.6				
		12	24	24	158	71.8				
24	X	3	12	12	90	40.9	23.20	23.60		
		4			93	42.3				
		6	16	15	97	44.1			23.80	24.20
		8	20	21	121	55.0			25.60	26.00
		10			127	57.7				
		12	24	24	167	75.9				

All dimensions are in inches.

HOW TO ORDER:

Determine the product number (**6626**), nominal main size, nominal outlet size and the high limit number (see table above) and then order by using the appropriate ordering code as shown in the following example. If a Stainless Steel Outlet Sleeve, with a 6" nominal outlet is required for a 12" nominal diameter HDPE pipe (12.75" OD), the ordering code is:

6626 - 12" x 6" - 12.95" i.e. **6626 - 12 x 6 - 12.95**
 product nom. main nom. outlet high end of
 number size size range

6626 Tapping Sleeves come in 3 sections for nominal pipe sizes of 18" - 24".

- Note:
- * - Size on size for IPS OD is not available.
 - For sizes not listed above, call ROBAR for availability.
 - The working range displayed is only a guideline, other ranges are available.

ROBAR INDUSTRIES LTD.

Surrey, British Columbia
 Phone: 1-800-663-6553

Boucherville, Quebec
 Phone: 1-800-315-9525

Calhoun, Georgia
 Phone: 1-706-624-4404

Website: www.robarindustries.com / E-mail: waterworks@robarindustries.com



6636AS

ABANDON SERVICE SLEEVE



APPLICATIONS:

ROBAR **6636AS** Abandon Service Sleeves are used to seal off abandoned or decommissioned 3/4" through 2" main stops. Allows for no disruption in water service. No re-chlorination of lines due to atmospheric exposure. Simply install over existing main stop. Available in bolt bracket style or lifter bar style.

MATERIAL SPECIFICATIONS:

Shell: T304 Stainless Steel, fully passivated*.
 Fasteners: 5/8" NC T304 Stainless Steel. Nuts coated with anti-galling compound. Torque is 70-80 ft. lbs.
 Gaskets: Ringseal: NBR (Buna N) Rubber.
 Liner: SBR (Buna S) Rubber.

Outlet Pipe: T304 Stainless Steel, fully passivated*.
 Outlet Size: 3" outlet size is used to cap 3/4" & 1" main stops. With a 3" outlet you have the option of having the fitting length 9" or 12".
 4" outlet size is used to cap 1-1/4" - 2" main stops. With a 4" outlet the standard fitting length is 12".

NOMINAL PIPE SIZE	BY X	OUTLET SIZE	FITTING LENGTH	NUMBER OF BOLTS	WORKING RANGE	
					LOW	HIGH
4	X	3	9 or 12	6 or 8	4.70	4.95
		4	12	8	4.95	5.20
6	X	3	9 or 12	6 or 8	6.40	6.80
		4	12	8	6.80	7.20
8	X	3	9 or 12	6 or 8	7.20	7.60
		4	12	8	8.40	8.80
10	X	3	9 or 12	6 or 8	8.80	9.20
		4	12	8	9.20	9.60
12	X	3	9 or 12	6 or 8	10.55	10.95
		4	12	8	10.90	11.30
14	X	3	9 or 12	6 or 8	11.30	11.70
		4	12	8	11.90	12.30
16	X	3	9 or 12	6 or 8	12.55	12.95
		4	12	8	13.00	13.40
18	X	3	9 or 12	6 or 8	13.40	13.80
		4	12	8	13.80	14.20
20	X	3	9 or 12	6 or 8	15.10	15.50
		4	12	8	15.50	15.90
24	X	3	9 or 12	6 or 8	15.80	16.20
		4	12	8	16.20	16.60
24	X	3	9 or 12	6 or 8	17.20	17.60
		4	12	8	17.40	17.80
24	X	3	9 or 12	6 or 8	17.80	18.20
		4	12	8	18.40	18.80
24	X	3	9 or 12	6 or 8	19.30	19.70
		4	12	8	19.80	20.20
24	X	3	9 or 12	6 or 8	20.20	20.60
		4	12	8	21.40	21.80
24	X	3	9 or 12	6 or 8	22.00	22.40
		4	12	8	22.60	23.00
24	X	3	9 or 12	6 or 8	23.80	24.20
		4	12	8	25.60	26.00

All dimensions are in inches.



HOW TO ORDER:

Determine the product number (**6636AS**), the nominal main size, the nominal outlet size and the actual main pipe OD, and then use the appropriate ordering code as shown in the following example.

To fit an Abandon Service Sleeve over 8" C900 pipe (9.05"OD) that has a 3/4" main stop attached, the ordering code would be:

6636AS - 8" x 3" - 9.05" i.e. **6636AS - 8 x 3 - 9.05**
 product nom. main nom. outlet actual main
 number size size OD

Note: * Refers to chemically treating Stainless Steel after welding ("Pickled/Passivated") to return it to its original appearance.
 - The high limit of the range is used in the ordering code.
 - Other sizes and variations available on request.

ROBAR INDUSTRIES LTD.

Surrey, British Columbia
 Phone: 1-800-663-6553

Boucherville, Quebec
 Phone: 1-800-315-9525

Calhoun, Georgia
 Phone: 1-706-624-4404

Website: www.robarindustries.com / E-mail: waterworks@robarindustries.com



6808 / 6806 / 6906

CARBON STEEL TAPPING SLEEVE



APPLICATIONS:

ROBAR 6808 / 6906 / 6906 Tapping Sleeves are used to make a branch outlet off a main supply line on Steel, Ductile Iron, Cast Iron, Asbestos Cement and C900 pipe. Not recommended for Concrete Pressure pipe or HDPE.

MATERIAL SPECIFICATIONS:

Body: Shell: Carbon Steel
 Outlet Pipe: Schedule 40 Carbon Steel or equivalent.

Flange: Carbon Steel as per AWWA C207 class D. Mechanical Joint flange available.

Fasteners: **6808/6908** - 3/4" NC HSLA.
6806/6906 - 3/4" NC T-304 Stainless Steel. Nuts coated with anti-galling compound. Torque is 80ft. lbs.

Gaskets: NBR (BUNA-N) rubber.

Test Plug: 3/4" NPT Carbon Steel.

Coatings: **6808/6806** - Enamel coated.
6908/6906 - Corrosion Protective Epoxy coating.

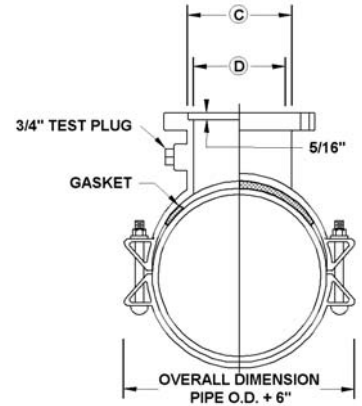

TAPPING SLEEVE DATA						
NOMINAL OUTLET SIZE	A	B	C (DIA.)	D (DIA.)	BOLT QTY.	BOLT SIZE
3	12	5.19	4.06	3	6	3/4
4	12	5.19	5.06	4	6	3/4
6	12	5.63	7.06	6	6	3/4
8	16	6.00	9.06	8	8	3/4
10	20	6.50	11.06	10	10	3/4
12	20	6.75	13.06	12	10	3/4

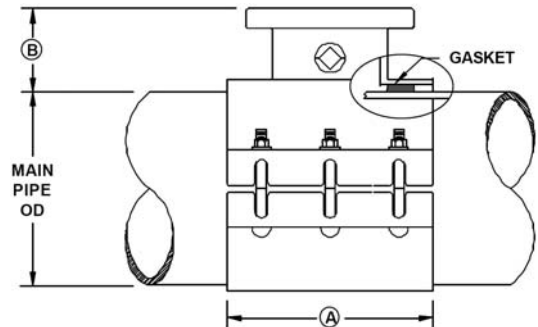

HOW TO ORDER:

Determine the product number (6808, etc.), nominal main size, nominal outlet size and the high limit number (see table above) and then order using the appropriate ordering code as shown in the following example.

If an Enamel coated mild steel tapping sleeve is required to install a 8" outlet on a 12" Ductile Iron pipe (13.20" OD), the ordering code is:

6808 - 12" x 8" - 13.30" i.e. **6808 - 12 x 8 - 13.30**
 product nom. main nom. outlet high end
 number size size

Carbon Steel tapping sleeves rated for 150 PSI working pressure (contact Robar for higher pressure ratings).



This product is tested and certified by WQA to NSF/ANSI standard 61

ROBAR INDUSTRIES LTD.

Surrey, British Columbia
Phone: 1-800-663-6553

Boucherville, Quebec
Phone: 1-800-315-9525

Calhoun, Georgia
Phone: 1-706-624-4404

Website: www.robarindustries.com / E-mail: waterworks@robarindustries.com



6808 / 6806 / 6906

CARBON STEEL TAPPING SLEEVE

NOMINAL PIPE SIZE	BY X	OUTLET SIZE	FITTING LENGTH	NUMBER OF BOLTS	APPROXIMATE SHIPPING WEIGHT		WORKING RANGE			
					LBS.	KG.	LOW	HIGH		
6	X	3	12	6	46	21	6.90	7.20		
		4			50	23				
		6**			50	23				
8	X	3	12	6	61	28	8.50	8.90		
		4			65	29				
		6			80	36				
		8**	16	8	90	41			9.30	9.70
10	X	3	12	6	64	29	9.70	10.10		
		4			68	31				
		6			70	32				
		8	16	8	92	42			10.50	10.90
		10**	20	10	118	54			10.90	11.30
12	X	3	12	6	88	40	12.10	12.50		
		4			92	42				
		6			100	45				
		8	16	8	115	52			12.50	12.90
		10	20	10	130	59			12.90	13.30
		12**	20	10	170	77			13.30	13.60
14	X	3	12	6	91	41	13.60	14.05		
		4			95	43				
		6			102	56				
		8	16	8	124	68			14.05	14.50
		10	20	10	150	91			14.50	14.95
		12	20	10	200	102			14.95	15.40
16	X	3	12	6	101	46	15.75	16.15		
		4			105	47				
		6			114	62				
		8	16	8	136	74			16.15	16.60
		10	20	10	162	96			16.60	17.05
		12	20	10	212	108			17.05	17.50
18	X	3	12	6	128	58	17.85	18.30		
		4			132	60				
		6			154	70				
		8	16	8	180	82			18.30	18.75
		10	20	10	230	105			18.75	19.20
		12	20	10	255	116			19.20	19.65
20 - 22	X	3	12	6	133	60	19.90	20.40		
		4			137	62				
		6			159	72				
		8	16	8	185	84			20.40	20.90
		10	20	10	235	107			20.90	21.40
		12	20	10	260	118			21.40	21.90
24	X	3	12	6	163	74	23.60	24.15		
		4			167	76				
		6			189	86				
		8	16	8	215	98			24.15	24.70
		10	20	10	265	120			24.70	25.25
		12	20	10	290	132			25.25	25.80

All dimensions are in inches.

For a 4" tapping sleeve, see **6606**, **6404** or **6506**.

Note: * The high limit of the range is used in the ordering code.
 ** When ordering size on size Tapping Sleeves, a 1/2" undersize cutter is required. Size on size for steel size is unavailable.
 - Other working ranges are available on request.

ROBAR INDUSTRIES LTD.

Surrey, British Columbia
 Phone: 1-800-663-6553

Boucherville, Quebec
 Phone: 1-800-315-9525

Calhoun, Georgia
 Phone: 1-706-624-4404

Website: www.robarindustries.com / E-mail: waterworks@robarindustries.com



6828 / 6926 SERIES 428

CARBON STEEL TAPPING SLEEVE



APPLICATIONS:



ROBAR **6828 / 6926** Tapping Sleeves are used to make a branch outlet off a main supply line on Steel, Ductile Iron, Cast Iron and Asbestos Cement pipe.

MATERIAL SPECIFICATIONS:

- Body: Carbon Steel plate.
 Flange: Drilled and faced per ANSI 150 lb. standards. Flat face recessed for tapping valve, per MSS standard SP-60. 300 lb. drilling available.
 Fasteners: **6828** - 3/4" NC Low alloy.
6926 - 3/4" NC T304 Stainless Steel. Nuts coated with anti-galling compound. Torque is 75-80 ft. lbs.
 Gaskets: NBR (Buna N) Rubber.
 Coatings: **6828** - Shop paint.
6926 - Corrosion Protective Epoxy coating.

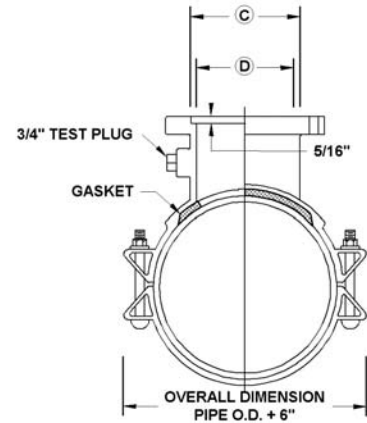

TAPPING SLEEVE DATA						
NOMINAL OUTLET SIZE	A	B	C (DIA.)	D (DIA.)	BOLT QTY.	BOLT SIZE
4	12	5.25	5.03	4.50	6	3/4
6	12	5.63	7.03	6.50	6	3/4
8	16	6.00	9.03	8.50	8	3/4
10	20	6.50	11.03	10.44	10	3/4
12	20	6.75	13.03	12.44	10	3/4
14	24	7.13	See Note Below		12	3/4
16	28	7.75			14	3/4
18	32	8.25			16	3/4
20	36	8.50			18	3/4

All dimensions are in inches.

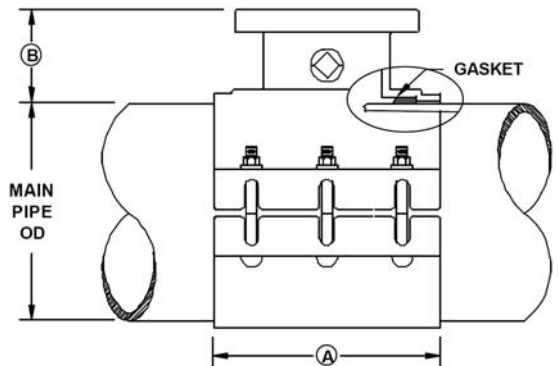

HOW TO ORDER:

Determine the product number (**6828, etc.**), the nominal main size, the nominal outlet size and the actual main pipe OD, and then use the appropriate ordering code as shown in the following example.

For a 16" Ductile Iron (17.40" OD) main, with an 8" branch in a corrosive ground condition (i.e. Epoxy coated with Stainless Steel bolts), the ordering code is:

6926 - 16" x 8" - 17.40" i.e. **6926 - 16 x 8 - 17.40**
 product nom. main nom. outlet actual main
 number size size OD

Note: - Flange outlets 14" and larger are designed to fit specific tapping valves of various manufacturers. Specify valve manufacturer when ordering branches 14" and larger.

ROBAR INDUSTRIES LTD.

Surrey, British Columbia
 Phone: 1-800-663-6553

Boucherville, Quebec
 Phone: 1-800-315-9525

Calhoun, Georgia
 Phone: 1-706-624-4404

Website: www.robarindustries.com / E-mail: waterworks@robarindustries.com



6898 / 6996

CONCRETE CYLINDER PIPE TAPPING SLEEVE



SIZES AVAILABLE:

16" to 120" Nominal Pipe OD on main supply line, 4" to 24" Nominal OD on branch line.

APPLICATIONS:

ROBAR **6898** or **6996** Concrete Cylinder Pipe Tapping Sleeves complement our existing line of Tapping Sleeves. These fabricated sleeves are designed to reinforce the concrete cylinder pipe when the structural wires are cut and have the additional benefit of being able to be very easily installed.

STANDARD FEATURES:

- Capable of working to 150 psi
- Oversized outlet for easy installation
- Broad gasket for sealing over weld areas
- Reinforced outlet seal face
- Installation of load bearing screws for valve support
- Shop coated over white metal cleaning
- 3 central grout holes
- Tapping valve location spigot

MATERIAL SPECIFICATIONS:

Body:	Carbon Steel plate (ASTM A-36)
Flange:	Drilled and faced per ANSI standards. Other drillings available. AWWA C207.
Gaskets:	NBR (Buna N) Rubber (AWWA C111).
Fasteners:	3/4" NC low alloy (AWWA C111). Torque to 75 ft. lbs.
Coating:	6898 Two coats of enamel.

OTHER CONFIGURATIONS:

6996: Epoxy coated body, **T316** Stainless Steel fasteners

HOW TO ORDER:

Determine the product number (**6898** or **6996**) and provide the following information:

1. OD of steel cylinder,
2. OD/thickness of concrete,
3. Outlet size,
4. Line pressure,
5. Line contents,
6. Solid back or straps
7. Brand name of tapping valve used, and
8. Any unusual conditions or requirements.

ROBAR INDUSTRIES LTD.

Surrey, British Columbia
Phone: 1-800-663-6553

Boucherville, Quebec
Phone: 1-800-315-9525

Calhoun, Georgia
Phone: 1-706-624-4404

Website: www.robarindustries.com / E-mail: waterworks@robarindustries.com



SECTION 7 FLANGED COUPLING ADAPTERS



7404
7406
7508
7506

Page 7.1.1



7808
7806
7908
7906

Page 7.2.1



7404DJ
7406DJ
7504DJ
7506DJ

Page 7.3.1



7808DJ
7806DJ
7908DJ
7906DJ

Page 7.3.1

ROBAR INDUSTRIES LTD.

Surrey, British Columbia
Phone: 1-800-663-6553

Boucherville, Quebec
Phone: 1-800-315-9525

Calhoun, Georgia
Phone: 1-706-624-4404

Website: www.robarindustries.com / E-mail: waterworks@robarindustries.com



7404 / 7406 / 7504 / 7506

CAST DUCTILE IRON FLANGED COUPLING ADAPTER



APPLICATIONS:

ROBAR 7404 / 7406 / 7506 Flanged Coupling Adapters are used to flexibly adapt plain end pipe to flanged end.

MATERIAL SPECIFICATIONS:

Flanged Body: Cast Ductile Iron, Class "D", C-207, with ANSI 150 lbs. drilling.
 End Ring: Cast Ductile Iron.
 Gaskets:
 Flange: NBR (Buna N) Rubber.
 Coupling: SBR (Buna S) Rubber.**
 Fasteners: **7404 / 7504** - NC Cast Ductile Iron, or Low Alloy Steel.
7406 / 7506 - Stainless Steel fasteners, fully passivated*.
 Nuts coated with anti-galling compound.
 Torque is 70-80 ft. lbs.
 Coatings: **7404 / 7406** - Two coats of Enamel.
7504 / 7506 - Epoxy coated Body and End Ring.

HOW TO ORDER:

Determine the product number (7404, etc.), nominal pipe OD, the actual OD (see table below) and then use the appropriate ordering code as shown in the following example.

For a standard FCA required for 6" C900 PVC pipe (6.90" OD), the ordering code is:

7404 - 6" - 6.90" i.e. **7404 - 6 - 6.90**
 product nom. OD actual OD or **7404 - 6 - A1**
 number size

NOMI- NAL PIPE SIZE	WORKING RANGE			END CODE	NUMBER OF FASTENERS	APPROXIMATE SHIPPING WEIGHT	
	LOW	OD	HIGH			LBS.	KG.
4	3.45	3.50	3.60	4T	4 - 5/8 X 7-1/4 Cross Bolt 4 - 5/8 x 4-1/8 T-Bolt 12 - 5/8" Nuts	19	8.6
	3.75		4.05	F3A			
	4.05		4.35	F3B			
	4.40	4.50	4.60	D3			
	4.74	4.80	5.10	A1			
	5.10		5.30	E5			
6	5.85		6.15	F3A	4 - 3/4 x 8 Cross Bolt 4 - 3/4 x 4-1/4 T-Bolt 12 - 3/4" Nuts	30	13.6
	6.15		6.45	F3B			
	6.50	6.63	6.70	D3			
	6.86	6.90	7.10	A1			
	7.15		7.35	E5			
8	7.90		8.25	F3A	4 - 3/4 x 8 Cross Bolt 4 - 3/4 x 4-1/4 T-Bolt 12 - 3/4" Nuts	38	17.2
	8.25		8.55	F3B			
	8.55	8.63	8.75	D3			
	8.99	9.05	9.30	A1			
	9.30		9.50	E5			
10	10.60	10.75	10.90	10T	6 - 7/8 x 9-3/8 Cross Bolt 6 - 7/8 x 5-1/8 T-Bolt 18 - 7/8" Nuts	56	25.4
	11.10	11.10	11.40	B2			
	11.55		11.75	A1			
	11.90		12.10	E5			
12	12.60	12.75	12.90	12T	6 - 7/8 x 9-3/8 Cross Bolt 6 - 7/8 x 5-1/8 T-Bolt 18 - 7/8" Nuts	72	32.6
	13.20	13.20	13.50	B2			
	13.80		14.10	A1			
	14.10		14.35	E5			

All dimensions are in inches.

Note: * Refers to chemically treating Stainless Steel after welding ("Pickled/Passivated") to return it to its original appearance.

** Other compounds available. Contact ROBAR for price and delivery.

ROBAR INDUSTRIES LTD.

Surrey, British Columbia
 Phone: 1-800-663-6553

Boucherville, Quebec
 Phone: 1-800-315-9525

Calhoun, Georgia
 Phone: 1-706-624-4404

Website: www.robarindustries.com / E-mail: waterworks@robarindustries.com



7808 / 7806 / 7908 / 7906

FABRICATED STEEL FLANGED COUPLING ADAPTER



APPLICATIONS:

ROBAR BAKER

ROBAR 7808 / 7806 / 7906 Flanged Coupling Adapters are used to flexibly adapt plain end pipe to flanged end.

MATERIAL SPECIFICATIONS:

Center Sleeve: Carbon Steel
 Flange: AWWA C207 Class D – ANSI 1021 150 lb. drilling. Class E or F Flanges available.
 End Ring: Mild Steel.
 Gaskets: SBR (Buna S) Rubber**.
 Fasteners: **7808/7908** - 5/8" NC Low Alloy fasteners.
7806/7906 - 5/8" Stainless Steel fasteners, fully passivated*. Nuts coated with anti-galling compound. Torque is 70-80 ft. lbs.
 Coatings: **7808/7806** - Two coats on enamel.
7908/7906 - Epoxy coated Center Sleeve and End Rings.

HOW TO ORDER:

Determine the product number (, etc.), nominal flange size, actual pipe OD and then use the appropriate ordering code as shown in the following example.

To couple a 16" OD Steel pipe (16.00" OD) to a 16" flanged connection, the ordering code is:

7808 - 16" - 16.00" i.e. **7808 - 16 - 16.00**
 product nom. flange actual
 number size OD

NOMINAL PIPE SIZE	OD OF FLANGE	NUMBER OF FLANGE BOLTS (CLASS D)	DIAMETER OF FLANGE BOLT CIRCLE	DIAMETER OF FLANGE BOLTS	THICKNESS OF FLANGE	APPROXIMATE SHIPPING WEIGHT	
						LBS.	KG.
4	9.00	8	7.50	.625	.625	36	16
6	11.00	8	9.50	.750	.688	40	18
8	13.50	8	11.75	.750	.688	55	25
10	16.00	12	14.25	.875	.688	62	28
12	19.00	12	17.00	.875	.812	93	42
14	21.00	12	18.75	1.000	0.938	120	54
16	23.50	16	21.25	1.000	1.000	165	75
18	25.00	16	22.75	1.125	1.062	180	82
20	27.50	20	25.00	1.125	1.125	200	91
24	32.00	20	29.50	1.250	1.250	255	116
30	38.75	28	36.00	1.250	1.375	350	159
36	46.00	32	42.75	1.500	1.625	395	180
42	53.00	36	49.50	1.500	1.750	600	272
48	59.50	44	56.00	1.500	1.875	780	354

All dimensions are in inches.

For sizes not listed above, contact ROBAR for availability.

- Note: * Refers to chemically treating Stainless Steel after welding ("Pickled/Passivated") to return it to its original appearance.
 ** Other compounds available. Contact ROBAR for price and delivery.
- When ordering, specify maximum working pressure.
 - No flange bolts or gaskets supplied.
 - Special coatings, gasket, flanges, fastener materials and isolating boots are available.
 - For price and availability, contact ROBAR and specify the pipe and flange sizes to be coupled along with any special requirements.

ROBAR INDUSTRIES LTD.

Surrey, British Columbia
Phone: 1-800-663-6553

Boucherville, Quebec
Phone: 1-800-315-9525

Calhoun, Georgia
Phone: 1-706-624-4404

Website: www.robarindustries.com / E-mail: waterworks@robarindustries.com



DISMANTLING JOINT

APPLICATIONS:



ROBAR **Dismantling Joint** allows for adjustability once the flange and other flange fitting is in place. Dismantling Joints provide longitudinal adjustment which allows for future modifications and adjustments. The dismantling joint provides an easier way of repairing or doing maintenance on the flanged pipe system.



SIZES AVAILABLE:

4" to 96" Nominal Pipe OD. Contact Robar for larger sizes.

MATERIAL SPECIFICATIONS:

- Flange Spool: AWWA C207 Class D Flange 150 lb Bolt Pattern (other flanges available)
- End Ring & Body: 4" - 12" Cast Ductile Iron, 14" and larger Carbon Steel ASTM A36
(4" - 12" available in Carbon Steel as well)
- Gaskets: SBR (Buna S) Rubber (other compounds available)
- Fasteners: **7404DJ / 7504DJ / 7808DJ / 7908DJ** - High Strength Low Alloy Fasteners or NC Cast Ductile Iron
7406DJ / 7506DJ / 7806DJ / 7906DJ - T-304 Stainless Steel
(other types of stainless steel available)
- Tie Rods: ASTM A193 Gr B7 per M11 (stainless steel is available)
- Coating: **7404DJ / 7406DJ / 7808DJ / 7806DJ** - Two coats of enamel
7504DJ / 7506DJ / 7908DJ / 7906DJ - Fusion Bonded Epoxy
(other types of epoxy available)

HOW TO ORDER:

Determine the product number (**7808DJ**, **7806DJ** or **7906DJ**), nominal size, actual OD of pipe, and pressure rating and then use the appropriate order code as shown in the following example:

To connect 16.00" OD steel pipe with 16" Flanges, that is epoxy coated and stainless steel bolts, the ordering code is:

7906DJ	-	16"	x	16.00"
product		Flange size		OD (Actual)
number				

i.e. **7906DJ - 16 x 16.00" OD**

ROBAR INDUSTRIES LTD.

Surrey, British Columbia
Phone: 1-800-663-6553

Boucherville, Quebec
Phone: 1-800-315-9525

Calhoun, Georgia
Phone: 1-706-624-4404

Website: www.robarindustries.com / E-mail: waterworks@robarindustries.com



SECTION 8 EXPANSION JOINTS



8808

8806

8908

8906

Page 8.1.1

ROBAR INDUSTRIES LTD.

Surrey, British Columbia
Phone: 1-800-663-6553

Boucherville, Quebec
Phone: 1-800-315-9525

Calhoun, Georgia
Phone: 1-706-624-4404

Website: www.robarindustries.com / E-mail: waterworks@robarindustries.com



8808 / 8806 / 8908 / 8906

FABRICATED STEEL EXPANSION JOINT



APPLICATIONS:

ROBAR BAKER

ROBAR 8808 Expansion Joints are used in Steel pipelines where large longitudinal pipe movements are concentrated. Use for piping water, gas, oil and various chemicals.

MATERIAL SPECIFICATIONS:

Flanges & Slip Pipe: Stainless Steel or Chrome Plated Mild Steel Slip Pipes are recommended for most permanent applications.

Fasteners: **8808/8908** - 5/8" electro-galvanized bolts.

8806/8906 - 5/8" T-316 Stainless Steel bolts. Nuts coated with anti-galling compound.
Torque is 70-80 ft. lbs.

Packing: Standard packing SBR Rubber / Jute, special packings are available.

End Preparation: Plain end - Bevelled for welding.

Flanged end - C207 Class D - ANSI 150 lb. drilling, other flanges available.
Grooved end also available.

Coating: **8808/8806** - Two coats of Enamel.

8908/8906 - Corrosion Protective Epoxy.

INSTALLATION:

The Expansion Joint may be contracted to 26-1/4" length or fully expanded to 36-1/4" length. The installer sets the length between these two extremes. The Slip Pipe is welded to one pipe in the line, and the joint Body is welded to the other pipe. Care should be taken to protect the gasket-bearing surfaces from corrosion or undue wear from line content or environment.

8808-1 (Style 1) 8906-1

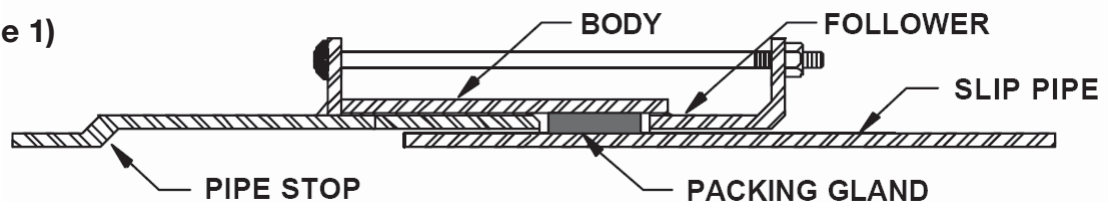

Construction: 8808-1 (Style 1) Expansion Joint is designed to satisfy the requirements of most applications. This style allows for up to 10" of longitudinal pipe movement, has one Slip Pipe and a single Packing Gland with no Limit Rods (see material specifications page 0.4.1).

8808-2 (Style 2) 8906-2

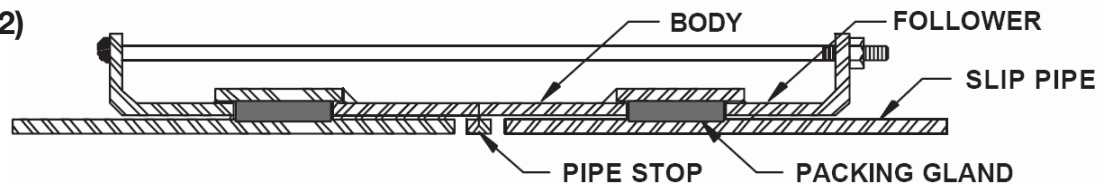

Construction: 8808-2 (Style 2) Similar to details of Style 1 Expansion Joint except that it has two Slip Pipes and two Packing glands. When the Joint Body is anchored, this style of Expansion Joint allows 4" of pipe movement at each end, for a total of 8".

ROBAR INDUSTRIES LTD.

Surrey, British Columbia
Phone: 1-800-663-6553

Boucherville, Quebec
Phone: 1-800-315-9525

Calhoun, Georgia
Phone: 1-706-624-4404

Website: www.robarindustries.com / E-mail: waterworks@robarindustries.com



8808 / 8806 / 8908 / 8906

FABRICATED STEEL EXPANSION JOINT

8808-3 (Style 3) 8906-3

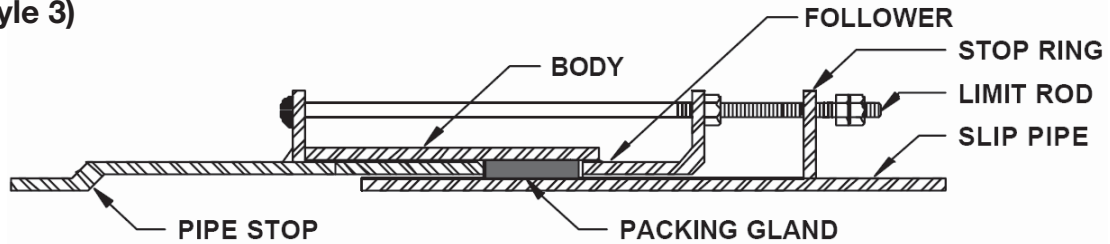

Construction: Similar to details of Style 1 Expansion Joint except that a Stop Ring is welded to the Slip Pipe, and the regular bolts are extended through this ring. A set of double nuts engages the Stop Ring to limit the Slip Pipe from pulling out of the joint.

8808-4 (Style 4) 8906-4

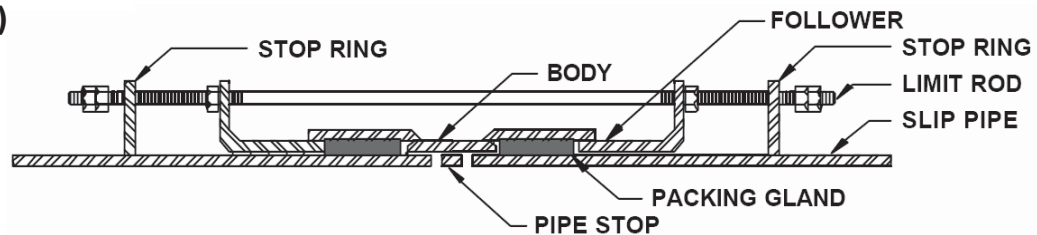

Construction: Similar to details of Style 2 Expansion Joints except that this style has two Stop Rings welded on the Slip pipes. As with Style 3, a set of double nuts engages each Stop Ring to limit the Slip Pipes from pulling out of the joint.

INFORMATION REQUIRED FOR ORDERING:

1. Total quantity required.
2. Type of pipe, wall thickness and exact OD of pipe.
3. Type and Style of Expansion Joint.
4. Service or line content - water, gas, sewage, etc.
5. Maximum working and test pressures (PSI).
6. Calculated movement at each joint, and frequency.
7. Minimum and maximum temperature ranges.
8. End preparation of pipe where Expansion Joint is required (flanged, beveled for welding, etc.).

HOW TO ORDER:

Determine the product number (,), the Expansion Joint style (Style 1, 2, 3, or 4), the exact pipe OD, the pipe ends required and then use the appropriate ordering code as shown in the following example.

For a 24" OD pipe on which 6" pipe movement is expected and you want beveled ends, the ordering code is:

8808 - 1 - 24.00" i.e. **8808 - 1 - 24.00 Bevel x Bevel**
 product style OD (Actual)
 number

Note: - All expansion joints are built to order. Allow for longer than normal delivery time.

ROBAR INDUSTRIES LTD.

Surrey, British Columbia
Phone: 1-800-663-6553

Boucherville, Quebec
Phone: 1-800-315-9525

Calhoun, Georgia
Phone: 1-706-624-4404

Website: www.robarindustries.com / E-mail: waterworks@robarindustries.com



SECTION 9 MISCELLANEOUS



**Drilling Machine
9010**

Page 9.1.1



Meter Coupling

9440

9540

9470

Page 9.2.1



Inserts

9626

Page 9.3.1



SlikStyx

Page 9.4.1



Back-up Flanges

9500

Page 9.5.1



**Pipe Support
Stand**

Page 9.6.1



**Flange Support
Stand**

Page 9.6.1



**Horseshoes
9999**

Page 9.7.1

ROBAR INDUSTRIES LTD.

Surrey, British Columbia
Phone: 1-800-663-6553

Boucherville, Quebec
Phone: 1-800-315-9525

Calhoun, Georgia
Phone: 1-706-624-4404

Website: www.robarindustries.com / E-mail: waterworks@robarindustries.com



9010

DRILLING MACHINE

NEW MODEL - NO EXTENSION REQUIRED:

The **9010** Drill Master is the result of 30 years of revisions to the original Dan-Dee drilling machine. It is made of the finest non-corrosive materials, with each machine being individually inspected prior to shipment. Its light weight, versatility, and ease of operation have made it a favorite of installers within the Waterworks Industry.

FOR DRILLING DI, CI, A/C, STEEL AND PLASTIC MAINS.

TYPE **9010**:

- A compact tool that drills mains for 3/4", 1", 1-1/4", 1-1/2" and 2" CC or IP Taps. (See manufacturer's notes.)
- Completes the operation before you can set up older, heavier machinery.
- Removes the coupon from the pipe - No drillings in your water system.
- For tapping (Hot & Dry) DI, CI, A/C, Steel and Plastic mains.
- Basic machine includes: ratchet wrench, pilot drill, allen wrench and carrying case. (See page 9.1.2)
- Machine weight: 7 lbs. Shipping weight w/carrying case: 17 lbs.

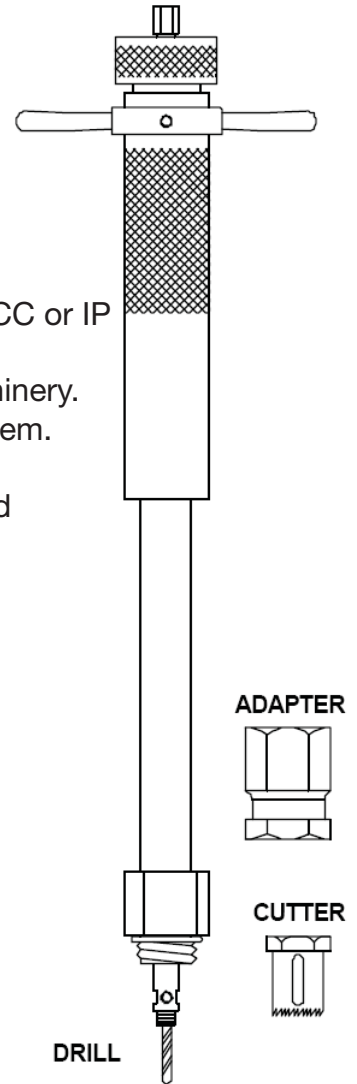

- Note:
- The **9010** is not recommended for use on any fluid distribution system other than water.
 - The use of mechanical assist tools such as drill motors or impact hammers is not recommended, as such use may bind the cutter and possibly break the stainless steel shaft.
 - Avoid the drilling of pipes with pressures in excess of 175 PSI, as higher pressures may blow out seals.
 - Observe all accepted safety precautions when operating machine.

ROBAR INDUSTRIES LTD.

Surrey, British Columbia
Phone: 1-800-663-6553

Boucherville, Quebec
Phone: 1-800-315-9525

Calhoun, Georgia
Phone: 1-706-624-4404

Website: www.robarindustries.com / E-mail: waterworks@robarindustries.com



APAC 9010

DRILLING MACHINE

	PART NUMBER	DESCRIPTION
	9010	Drilling Machine - Manual operation c/w Carrying Case
	902-048	1 1/2" Adapter for corp. stops with compression outlets
	902-049	2" Adapter for corp. stops with compression outlets
	902-050	3/4" Adapter for corp. stops with compression outlets
	902-051	3/4" IP Adapter
	902-052	1" Adapter for corp. stops with compression outlets
	902-053	1" IP Adapter
	902-054	1 1/4" Adapter for corp. stops with compression outlets
	902-055	1 1/4" IP Adapter
	902-056	1 1/2" Copper Adapter *Not common
	902-057	1 1/2" IP Adapter
	902-058	2" Copper Adapter *Not common
	902-059	2" IP Adapter
	903-071	11/16" Hole Saw (for 3/4" high speed)
	903-072	7/8" Hole Saw (for 1" high speed)
	903-073	1 1/8" Hole Saw (for 1 1/4" high speed)
	903-074	1 3/8" Hole Saw (for 1 1/2" high speed)
	903-075	1 7/8" Hole Saw (for 2" high speed)
	905-040	11/16" Hole Saw (for 3/4" Carbide tipped)
	905-041	7/8" Hole Saw (for 1" Carbide tipped)
	905-042	1 1/8" Hole Saw (for 1 1/4" Carbide tipped)
	905-043	1 3/8" Hole Saw (for 1 1/2" Carbide tipped)
	905-044	1 7/8" Hole Saw (for 2" Carbide tipped)
A	908-080	Ratchet Wrench
B	908-081	Shaft Drive Nut
C	908-082	Brass Bearing Cap
D	908-083	Feed Hand Wheel
E	908-084	Feed Wheel Set Screw
F	908-085	Thrust Bearing
G	908-086	Brass Feed Tube
H	908-087	Teflon Wiper
I	908-088	Metal Snap Ring
J	908-089	Brass Body
K	908-090	O-Ring Packing
L	908-091	Gasket (machine to adapter)
M	908-092	SS Shaft
N	908-093	Shaft Snap Ring
O	908-094	Pilot Drill
P	908-095	Set Screw
Q	908-096	Allen Wrench
	908-097	Shell Cutter Bushing

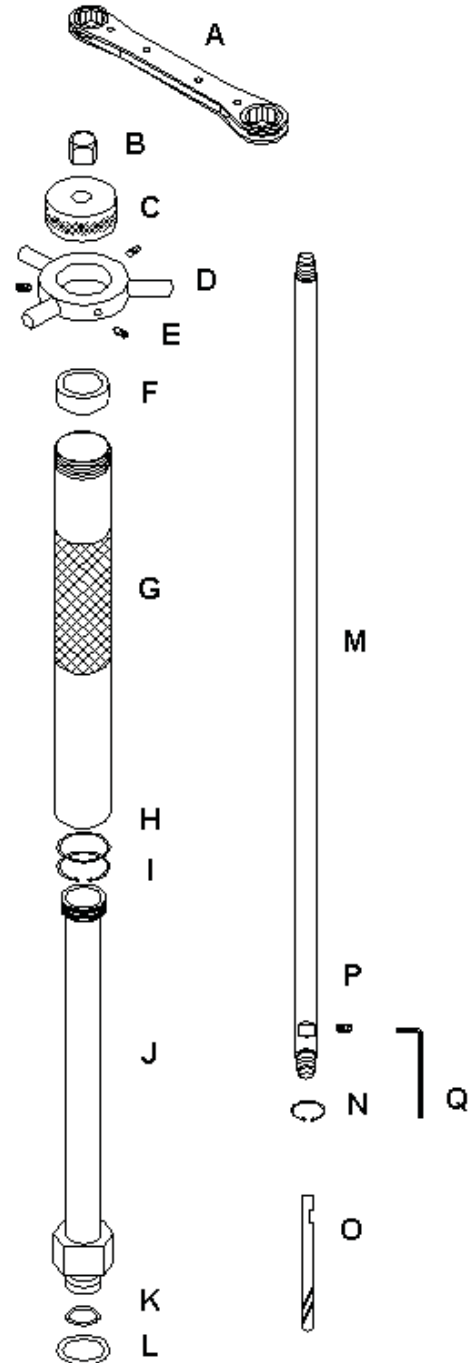

Note: - Shell Cutter Bushing is required for using 1-1/2" and 2" Hole Saw Cutters.

ROBAR INDUSTRIES LTD.

Surrey, British Columbia
Phone: 1-800-663-6553

Boucherville, Quebec
Phone: 1-800-315-9525

Calhoun, Georgia
Phone: 1-706-624-4404

Website: www.robarindustries.com / E-mail: waterworks@robarindustries.com



9440 / 9450 / 9470

METER COUPLING FLANGE

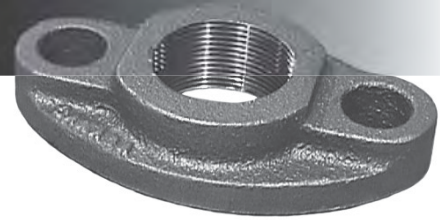

APPLICATIONS:

ROBAR **9440 / 9450 / 9470** Meter Coupling Flanges are used to mate with Flanged Water Meters.

MATERIAL SPECIFICATIONS:

Body: **9440** - Cast Ductile Iron.
9450 - Cast Ductile Iron.
9470 - 85-5-5-5 Brass.
O-Ring: NBR (Buna N) Rubber.
Coating: **9440** - Two coats of Enamel.
9450 - Corrosion Protective Epoxy coating.
9470 - Not coated. (Waterworks Bronze)

NOMINAL SIZE	PRODUCT NUMBER	APPROXIMATE SHIPPING WEIGHT	
		LBS.	KG.
1 1/2	9440	2.25	1.1
	9450	2.25	1.1
	9470	2.07	1.2
2	9440	2.75	1.3
	9450	2.75	1.3
	9470	3.00	1.4

All dimensions are in inches.

HOW TO ORDER:

Determine the product number (**9440, etc.**) and nominal size and then use the appropriate ordering code (see table above) as shown in the following example.

For a 2" Meter Flange in Enamel coated Ductile Iron, the ordering code is:

9440 - 2 i.e. **9440 - 2**
product size
number

ROBAR INDUSTRIES LTD.

Surrey, British Columbia
Phone: 1-800-663-6553

Boucherville, Quebec
Phone: 1-800-315-9525

Calhoun, Georgia
Phone: 1-706-624-4404

Website: www.robarindustries.com / E-mail: waterworks@robarindustries.com



9626

STAINLESS STEEL ADJUSTABLE INSERT



APPLICATIONS:

ROBAR **9626** Adjustable Inserts are for use on thin wall PVC or High Density Polyethylene pipe, to add hoop strength to pipe when using ROBAR couplings, repair clamps or restraining devices. When using restraint, be sure the length is long enough to be within the restraint length.

MATERIAL SPECIFICATIONS:

T304 stainless steel, fully passivated*.

HOW TO ORDER:

Determine the product number (**9626**) and exact Inside Diameter of PVC or High Density Polyethylene pipe and the insert length (6", 8" or 12") and then order by using the appropriate ordering code as shown in the following example.

For an 8" long insert required for a 6" DR17 High Density Polyethylene pipe (5.798" ID), the ordering code is:

9626 - 5.798" x 8" i.e. **9626 - 5.798 x 8**
product inside insert
number diameter length

4" - 14" inserts are fabricated in 16 gauge T-304 Stainless Steel.

16" and larger inserts are fabricated in 12 gauge T-304 Stainless Steel.

POLYETHYLENE PIPE / IRON PIPE SIZES								
NOMI- NAL PIPE OD	DR 32.5		DR 21		DR 17		DR 11	
	AVG. INSIDE DIAMETER	MIN. WALL THICKNESS	AVG. INSIDE DIAMETER	MIN. WALL THICKNESS	AVG. INSIDE DIAMETER	MIN. WALL THICKNESS	AVG. INSIDE DIAMETER	MIN. WALL THICKNESS
4"			4.046	0.214	3.938	0.265	3.633	0.409
6"	6.193	0.204	5.957	0.315	5.798	0.39	5.349	0.602
8"	8.063	0.265	7.754	0.411	7.55	0.507	6.963	0.784
10"	10.048	0.331	9.665	0.512	9.41	0.632	8.679	0.977
12"	11.919	0.392	11.463	0.607	11.16	0.75	10.293	1.159
14"	13.086	0.431	12.586	0.667	12.253	0.824	11.301	1.273
16"	14.957	0.492	14.385	0.762	14.005	0.941	12.915	1.455
18"	16.826	0.554	16.183	0.857	15.755	1.059	14.532	1.636
20"	18.696	0.615	17.982	0.952	17.507	1.176	16.146	1.818
22"	20.565	0.677	19.778	1.048	19.257	1.294	17.76	2.000
24"	22.435	0.738	21.577	1.143	21.007	1.412	19.374	2.182

All dimensions are in inches.

Note: * Refers to chemically treating Stainless Steel after welding ("Pickled/Passivated") to return it to its original appearance.
- **9626** Adjustable inserts are available for 5.349" ID and larger. Fixed inserts are available from 2.83" ID. Exact ID is required for fixed inserts.
- Larger sizes are available upon request.

ROBAR INDUSTRIES LTD.

Surrey, British Columbia
Phone: 1-800-663-6553

Boucherville, Quebec
Phone: 1-800-315-9525

Calhoun, Georgia
Phone: 1-706-624-4404

Website: www.robarindustries.com / E-mail: waterworks@robarindustries.com



SLIKSTYX



The first Spray-On lubricant for all gasketed pipes:

- Works in all temperature extremes and conditions.
- Convenient & Efficient.
- Less Mess - Just point and shoot.
- No Waste - You don't lose any lubricant due to dropping or contamination.
- Cost Savings - Nearly 3 times the coverage as conventional lube.
- Bright Colour - Sprays on yellow so you can see the area lubricated.

16 oz. SLIKSTYX
Item # ROB 101

One 16 oz can of **SLIKSTYX** covers as much as three 2# tubs of lube.

Note: - SLIKSTYX is NSF61 compliant. Only those products bearing the NSF61 logo stamp are compliant.



ROBAR INDUSTRIES LTD.

Surrey, British Columbia
Phone: 1-800-663-6553

Boucherville, Quebec
Phone: 1-800-315-9525

Calhoun, Georgia
Phone: 1-706-624-4404

Website: www.robarindustries.com / E-mail: waterworks@robarindustries.com



9500

FRP BACK-UP FLANGES



APPLICATIONS:

Robar 9500 FRP Back-up Flanges are used to couple fiberglass pipes. Typically suited for lines with corrosive chemicals. The flanges conform to ASA B16.5 standard with a 150 pound bolt pattern.

MATERIAL SPECIFICATIONS:

Body: Cast Ductile Iron per ASTM A536 standard.
 Coating: Fusion bonded epoxy coated per AWWA C-213 standard.
 Pressure: Up to 150 PSI working pressure.
 Sizes Available: 1"– 30"

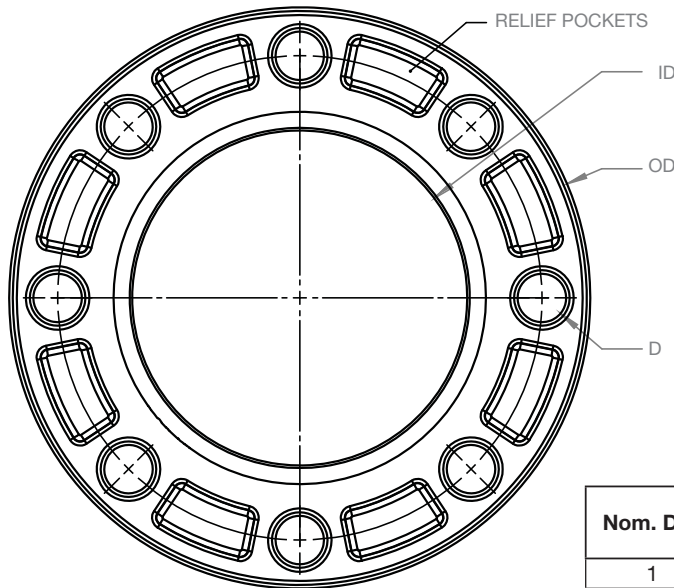

Nom. Dia.	ID	OD	D (Bolt Hole Dia.)	# Bolt Holes
1	1 15/16	4 1/2	5/8	4
1.5	2 1/4	5	5/8	4
2	3 1/8	6	3/4	4
2.5	3 1/2	7	3/4	4
3	4 3/8	7 1/2	3/4	4
4	5 3/16	9	3/4	8
6	7 11/16	11	7/8	8
8	9 3/4	13 1/2	7/8	8
10	12	16	1	12
12	14 7/8	19	1	12
14	16 1/2	21	1 1/8	12
16	18 3/4	23 1/2	1 1/8	16
18	20 1/4	25	1 1/4	16
20	22 3/8	27 1/2	1 1/4	20
24	26 3/4	32	1 3/8	20
30	33	38 3/4	1 3/8	28

Note: Not to be used as HDPE Back up Flange.

- All dimensions are in inches

ROBAR INDUSTRIES LTD.

Surrey, British Columbia
 Phone: 1-800-663-6553

Boucherville, Quebec
 Phone: 1-800-315-9525

Calhoun, Georgia
 Phone: 1-706-624-4404

Website: www.robarindustries.com / E-mail: waterworks@robarindustries.com



PIPE SUPPORT STAND

APPLICATIONS:

The Robar Pipe Support Cradle stand is available from 2" - 36".

MATERIAL SPECIFICATIONS:

Base Plate:	ASTM A36 Carbon Steel
Sleeve:	ASTM A53 ERW Tubing
Stud:	ASTM A36, Rolled Thread
Coating:	Two coats of Enamel or Corrosion Epoxy Coated

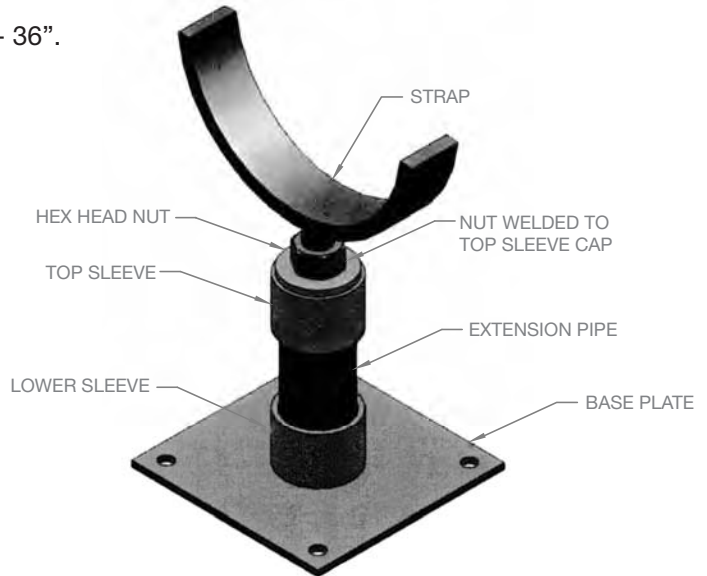

Note: - All pipe cradle stands are formed to Ductile Iron radius.
 - Extension pipe is not supplied. Customer to supply own 2" schedule 40 pipe and field cut to required length.



FLANGE SUPPORT STAND

APPLICATIONS:

The Robar Pipe Support Flange stand is available from 3" - 24".

MATERIAL SPECIFICATIONS:

Base Plate:	ASTM A36 Carbon Steel
Sleeve:	ASTM A53 ERW Tubing
Stud:	ASTM A36, Rolled Thread
Coating:	Two coats of Enamel or Corrosion Epoxy Coated

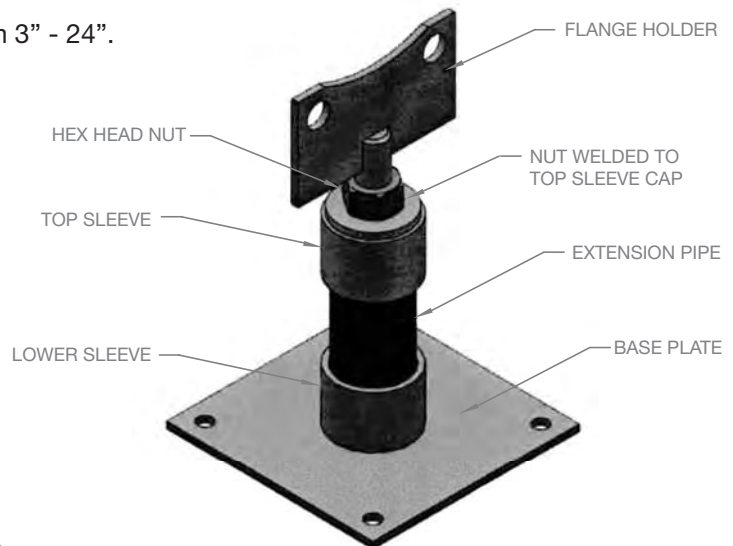

Note: - Extension pipe is not supplied. Customer to supply own 2" schedule 40 pipe and field cut to required length.

ROBAR INDUSTRIES LTD.

Surrey, British Columbia
 Phone: 1-800-663-6553

Boucherville, Quebec
 Phone: 1-800-315-9525

Calhoun, Georgia
 Phone: 1-706-624-4404

Website: www.robarindustries.com / E-mail: waterworks@robarindustries.com



9999

CAST DUCTILE IRON RECREATIONAL HORSESHOES

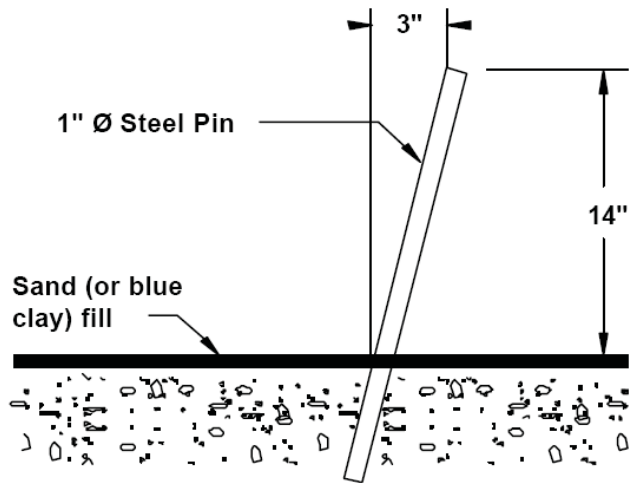
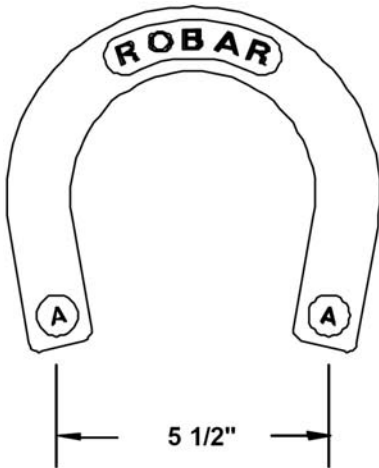

Maximum Weight is 2-1/2 LBS.
Two pairs of shoes in a set.
Each pair is identified as "A" or "B".

THE COURT

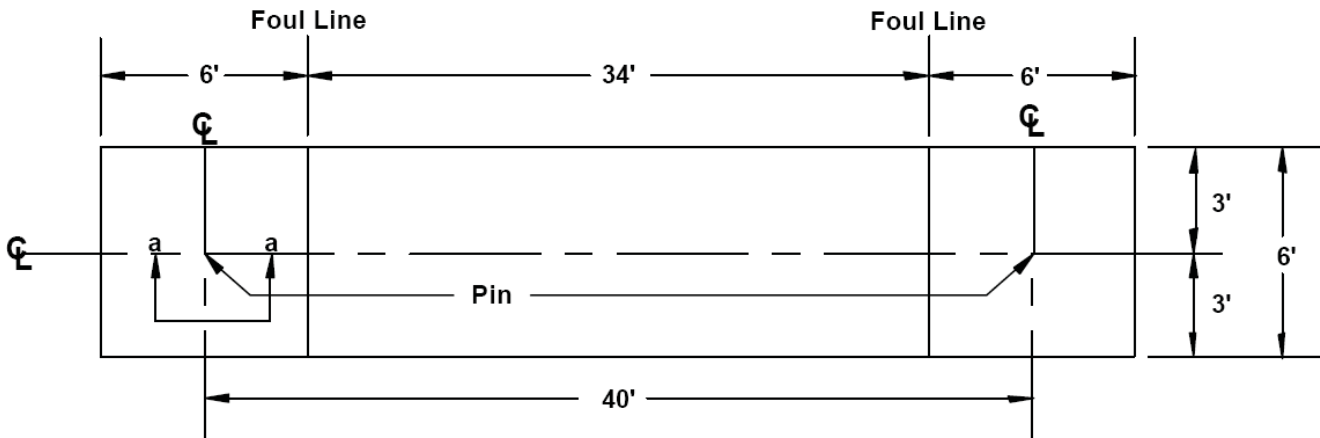

Note: - Pins not supplied by ROBAR.

ROBAR INDUSTRIES LTD.

Surrey, British Columbia
Phone: 1-800-663-6553

Boucherville, Quebec
Phone: 1-800-315-9525

Calhoun, Georgia
Phone: 1-706-624-4404

Website: www.robarindustries.com / E-mail: waterworks@robarindustries.com



SECTION 10 INSTALLATION INSTRUCTIONS



1400 / 1500
Page 10.1.1



1606
Page 10.2.1



1800 / 1900
Page 10.3.1



2408
Page 10.4.1



2606
Page 10.5.1



2706
Page 10.6.1



5616
Page 10.7.1



5626
Page 10.8.1



5636
Page 10.9.1



6400 / 6500
Page 10.11.1



6606
Page 10.12.1



6626
Page 10.14.1



6636AS
Page 10.15.1



6800 / 6900
Page 10.16.1



7400 / 7500
Page 10.17.1



9626
Page 10.18.1

ROBAR INDUSTRIES LTD.

Surrey, British Columbia
Phone: 1-800-663-6553

Boucherville, Quebec
Phone: 1-800-315-9525

Calhoun, Georgia
Phone: 1-706-624-4404

Website: www.robarindustries.com / E-mail: waterworks@robarindustries.com



1400/1500 COUPLING

INSTALLATION GUIDE



1. Visually inspect the coupling to ensure it is of the required outside diameter for the desired application. Make sure the coupling is complete and there are no missing nuts, bolts or washers.
2. Clean the pipe ends to ensure that all dirt and irregularities have been removed.
3. Disassemble the coupling and slide the appropriate end rings over the appropriate pipe.
4. Lubricate the coupling gaskets and the pipe with potable, NSF certified lube. ROBAR recommends SLIKSTYX.
5. Slide the appropriate gasket over the pipe. The tapered end must face the pipe ends.
6. Slide the center ring over the pipe, and position the center ring over the pipe gap. Note: For minimum and maximum pipe gaps refer to AWWA C-219.
7. Push the gaskets and end rings into position against the center rings. Be sure to maintain an equal spacing between the 2 pipe sections.
8. Slide the bolts into place and tighten nuts using a torque wrench. Torque each bolt alternating between bolts in a “star” pattern to 80 ft. lbs.
9. Pressure test the pipeline prior to backfilling..

CAUTION



Couplings do not prevent pipe pullout.
Suitable restraint should be used when required.

ROBAR INDUSTRIES LTD.

Surrey, British Columbia
Phone: 1-800-663-6553

Boucherville, Quebec
Phone: 1-800-315-9525

Calhoun, Georgia
Phone: 1-706-624-4404

Website: www.robarindustries.com / E-mail: waterworks@robarindustries.com



1606 COUPLING

INSTALLATION GUIDE



1. Check to ensure that the OD of the pipe corresponds with the coupling being installed.
2. Ensure that the pipe surface is clean and free of irregularities.
3. Lubricate pipes and the inside of the gasket to aid the installation procedure and to allow the gasket to seat more uniformly on the pipe.
4. Slide the gasket onto one of the pipes being coupled.
5. Line up the two lengths of pipe and slide the gasket, centering the gasket over the joint.
6. Ensure that the pipes are in line when the coupling is installed. Any deflection should be achieved after installation and should be kept to a minimum. For more details contact ROBAR's Technical Sales Department. Pipe gap should be kept below 1".
7. Lubricate the outside of the gasket to allow the stainless steel shell to slide smoothly over the gasket during the torquing procedure. ROBAR recommends NSF61 certified SLIKSTYX.
8. Install the stainless steel shell over the gasket, sliding the lifter bar(s) over and behind the lugs.
9. Tighten nuts in random sequence and in uniform steps up to approximately 75-80 ft. lbs. of torque.
10. Pressure test line prior to backfilling.
11. For recommended working pressures and specifications, consult the ROBAR **1606** Product Information.

ROBAR Adjustable Inserts are recommended on flexible plastic pipe, such as Polyethylene, to provide internal pipe support.

CAUTION



Couplings do not prevent pipe pullout.
Suitable restraint should be used when required.

ROBAR INDUSTRIES LTD.

Surrey, British Columbia
Phone: 1-800-663-6553

Boucherville, Quebec
Phone: 1-800-315-9525

Calhoun, Georgia
Phone: 1-706-624-4404

Website: www.robarindustries.com / E-mail: waterworks@robarindustries.com



1800/1900 COUPLING INSTALLATION GUIDE



PIPE ENDS:

1. Measure pipe diameter at 8 places 45 deg. apart. Difference between minimum and maximum should not exceed $\frac{1}{8}$ (C). If the difference is greater than $\frac{1}{8}$ (C), make corrections by rounding up the pipe with trench jacks, or suitable wooden post and wedges. Maintain this roundness until the joint is made up, and all torquing has been completed.
***Refer to TABLE ON PIPE END TOLERANCES on Page 10.3.2**
2. Pipe ends must be clean and free of all oil, dirt, loose scale & rust. A thorough cleaning with a wire brush is recommended. All welds on pipe ends must be ground smooth.

ASSEMBLY:

1. Place an end ring on each pipe end. If the end ring(s) does not easily slip on pipe, correct pipe out-of-roundness with jacks or posts as noted above in 1.
2. The gaskets should be cleaned and inspected for any damage in shipment. **Lubricate the coupling gaskets** and the pipe with potable, NSF certified lube. ROBAR recommends SLIKSTYX.
3. Place the center sleeve on one pipe end. Place gasket and other end ring on the other pipe end. **Slide the center sleeve into position and center over gap between the two pipe ends.**
4. **IMPORTANT:** The clearance between the OD of the pipe ends and the ID of the center sleeve and end rings is to be distributed as evenly as possible. **No more than 1/8" gap or opening is permissible.** Wooden wedges or plastic shims may be used. These centering aids may be removed after the coupling is assembled. The wedges or shims must not project into the gasket pocket.
5. Be sure that the gasket pocket in the end ring(s) is free from wood, dirt, metal or other field debris.
6. Apply *flax soap to the gasket and center sleeve bevel face, a push gaskets into place. (In winter, use ethylene glycol mixture).
7. Push end rings against gasket, and rotate one end ring until bolt holes line up.

BOLTING UP:

1. Insert all bolts, tighten nuts finger tight. It is convenient to tighten bolts by downward wrenching. Insert bolts so nuts are on the left side of the installer, as he faces the pipe. **STAINLESS STEEL NUTS SHOULD BE FIELD LUBRICATED WITH A SUITABLE ANTI GALLING COMPOUND PRIOR TO BOLT TIGHTENING.**
2. Be certain that the end ring(s) is started over the center sleeve without any interference. If necessary, wedges may be used to free the end ring(s) from the edge of the center sleeve.

BOLTED SLEEVE TYPE COUPLINGS DO NOT PROVIDE PROTECTION AGAINST PULLOUT OF PIPE.

ROBAR INDUSTRIES LTD.

Surrey, British Columbia
Phone: 1-800-663-6553

Boucherville, Quebec
Phone: 1-800-315-9525

Calhoun, Georgia
Phone: 1-706-624-4404

Website: www.robarindustries.com / E-mail: waterworks@robarindustries.com



1800/1900 COUPLING

INSTALLATION GUIDE

- On couplings 60" and larger, 3 or 4 installers can best tighten. Space the installers equally around the coupling, and have all advance in the same direction as they tighten each nut. Be certain that the end ring does not "cock" as the nuts are tightened. A torque-limiting wrench must be used. Tighten to 30 – 35 foot pounds all around, two or three times. Increase the wrench setting to 40 – 50 foot pounds, and continue the procedure to 75 foot pounds for 5/8" bolts and 90 foot pounds for 3/4" and larger bolts. At the maximum tightness, go around the coupling several times to assure uniform gasket pressure.
- Before final tightening, it is good technique to strike each head with a light sledge hammer to seat all parts.
- AFTER FINAL TIGHTENING HAS BEEN COMPLETED**, remove all pipe roundup material.

Retightening of bolts: After 24 hours, or just before filling with water, it may be necessary to check the tightness of the bolts. Follow the last torque setting as shown above.

Testing: If leaks develop during the test procedure, tighten as necessary to stop leaks. Caution should be exercised to assure that end ring, center sleeve or the bolting hardware is not overstressed during this tightening procedure.

CAUTION: A pipe section should never be allowed to HANG in the coupling, either before or after making up the joint. Couplings are designed to FLOAT on pipe ends, not support the pipe.

Pipe End Preparation: The pipe shall be sufficiently free from indentations, projections, or roll marks for a distance 18" from the end of the pipe to make a tight joint with the rubber gasket type of coupling. For a distance of 18" from the end of the pipe, the pipe circumference shall not be more than (A) larger or (B) smaller than the outside circumference computed from the specified outside diameter. All of the out-of-roundness shall be in the form of a smooth oval that can be jacked round in such a manner that the difference between the maximum and minimum diameters shall not exceed (C).

TABLE ON PIPE END TOLERANCES			
PIPE OD	(A) (+) TOL	(B) (-) TOL	(C) MIN MAX
12"–42" Follow AWWA C-219-11, Table 4 Page 14 for all applications			
44"– 72"	1/8"	1/16"	1/8"
73"– 96"	3/16"	1/16"	1/8"
97"–120"	1/4"	1/16"	3/16"
120" & UP	1/4"	1/16"	1/4"

- Note:
- Flanged Coupling Adapters may be installed using these instructions.
 - **INSULATING BOOT(s). Position boot(s) over pipe end(s), then follow these instructions from the beginning.**
 - **IMPORTANT. ASSEMBLY 4, above, is modified so that 1/4" opening at any one place is permitted prior to the boot(s) being inserted over the pipe ends.**
 - **BOLTED SLEEVE TYPE COUPLINGS DO NOT PROVIDE PROTECTION AGAINST PULLOUT OF PIPE.**
 - Robar follow the provisions outlined in AWWA C-219 when manufacturing **BOLTED SLEEVE TYPE COUPLINGS, FLANGED COUPLING ADAPTERS**, or related products.

ROBAR INDUSTRIES LTD.

Surrey, British Columbia
Phone: 1-800-663-6553

Boucherville, Quebec
Phone: 1-800-315-9525

Calhoun, Georgia
Phone: 1-706-624-4404

Website: www.robarindustries.com / E-mail: waterworks@robarindustries.com



2408 SERVICE SADDLE

INSTALLATION GUIDE



1. Visually inspect the Service Saddle to ensure it is the required nominal and outlet size for the desired application. Make sure that the saddle is complete and that there are no missing nuts or washers.
2. Completely remove straps from the saddle body and check the fit of the saddle on the pipe. Note: **2408** Saddles are designed for use on RIGID PIPE ONLY (DI, Steel, A/C).
3. Clean the entire circumference of the pipe where the saddle is to be installed. Make sure to clean the threads with a wire brush to remove any sand or dirt. Lubricate the saddle gasket with a potable, NSF certified lube. ROBAR recommends SLIKSTYX.
4. Position the saddle on the pipe and install the straps. Hand tighten the nuts while making sure that the straps are positioned evenly. Be sure to avoid rotating the saddle once this has been done. Using a torque wrench, tighten the nuts evenly and incrementally in a cross pattern to 45 ft. lbs. A cross pattern tightening method allows for even and positive gasket seating.

ROBAR INDUSTRIES LTD.

Surrey, British Columbia
Phone: 1-800-663-6553

Boucherville, Quebec
Phone: 1-800-315-9525

Calhoun, Georgia
Phone: 1-706-624-4404

Website: www.robarindustries.com / E-mail: waterworks@robarindustries.com



2606 SERIES

INSTALLATION GUIDE



1. Visually inspect the Service Saddle to ensure it is the required nominal and outlet size for the desired application. Make sure that the saddle is complete and that there are no missing nuts, washers or lifter bar(s).
2. Open section (or sections) of saddle by backing off the nuts to end of the bolts. To avoid loss or misplacement of these components and to ease installation, do not completely remove nuts.
3. Clean the entire circumference of the pipe where the saddle is to be installed. Make sure to clean the threads with a wire brush. Galling WILL occur if there is sand or dirt on the threads, leaving the impression that the correct torque level has been reached. Lubricate the saddle gasket with a potable, NSF certified lube. ROBAR recommends SLIKSTYX.
4. 2616 (Style 1) - Position the saddle on the pipe. Snap the lifter bar into position. Hand tighten the saddle onto the pipe. Be sure to avoid rotating the saddle once this has been done. Using a torque wrench, tighten the nuts incrementally to the specified torque value as marked on the saddle. Be sure to alternate between studs while tightening.

TORQUE VALUES

All Sizes Boss-Pad Gasket: 80 ft-lbs.

5. 2626/2636 (Style 2 & 3) - Position the outlet section of the saddle on pipe. Snap the lifter bars into position and hand tighten the saddle onto the pipe. Be sure to avoid rotating the saddle once this has been done. Using a torque wrench, tighten the nuts incrementally and in a crossing pattern to the specified torque value marked on the saddle. Make every effort to maintain an equal distance between the saddle sections.

TORQUE VALUES

All Sizes Boss-Pad Gasket: 80 ft-lbs.

6. Once torque has been achieved, inspect for proper fit and positioning. Install the main stop using Teflon tape. DO NOT over tighten the main stop as this will distort the outlet. Check for leaks. If leak occurs, remove saddle and re-install. Do not over tighten. If for any reason the gasket has been damaged, do not use.
7. Once the main stop has been installed into the saddle and the branch line has been successfully pressurized, DO NOT BEND or EXERT EXTERNAL PRESSURE on pipe leading to the saddle. Any slight distortion on the saddle shell (near outlet) is considered a bad installation. Be sure to re-tighten saddle to specified torque values after tapping operation and before backfilling.

ROBAR INDUSTRIES LTD.

Surrey, British Columbia
Phone: 1-800-663-6553

Boucherville, Quebec
Phone: 1-800-315-9525

Calhoun, Georgia
Phone: 1-706-624-4404

Website: www.robarindustries.com / E-mail: waterworks@robarindustries.com



2706 SERVICE SADDLE

INSTALLATION GUIDE



1. Visually inspect the Service Saddle to ensure it is the required nominal and outlet size for the desired application. Make sure that the saddle is complete and that there are no missing nuts or washers.
2. Completely remove straps from the saddle body and check the fit of the saddle body on the pipe. The saddle should not sit "proud" on the pipe and the saddle ears should not dig into the pipe.
3. Clean the entire circumference of the pipe where the saddle is to be installed. Make sure to clean the threads with a wire brush. Galling WILL occur if there is sand or dirt on the threads, leaving the impression that the correct torque level has been reached. Lubricate the saddle gasket with a potable, NSF certified lube. ROBAR recommends SLIKSTYX.
4. Position the saddle on the pipe and install the straps. Hand tighten the nuts while making sure that the straps are positioned evenly. Be sure to avoid rotating the saddle once this has been done. Using a cross pattern, tighten the nuts evenly and incrementally to 45 ft. lbs. A cross pattern tightening method allows for even and positive gasket seating.
5. Once torque has been achieved, inspect for proper fit and positioning. Install the main stop using Teflon Tape. Check for leaks. Be sure to re-tighten the saddle to 45 ft. lbs. after tapping operation and before backfilling.

ROBAR INDUSTRIES LTD.

Surrey, British Columbia
Phone: 1-800-663-6553

Boucherville, Quebec
Phone: 1-800-315-9525

Calhoun, Georgia
Phone: 1-706-624-4404

Website: www.robarindustries.com / E-mail: waterworks@robarindustries.com



5616 REPAIR CLAMP

INSTALLATION GUIDE



*A standard feature of the **5616** (Style 1) ROBAR Repair Clamp is its ease of installation. All Robar Repair Clamps are pre-formed at the factory, allowing for easy installation.*

1. Remove the clamp from its box. Ensure it has the required outside diameter for the desired application. Visually inspect the repair clamp to make certain there are no missing nuts, washers, or lifter bars.
2. Open the clamp by backing off the nuts to the end of the bolts. To avoid loss or misplacement of components, do not completely remove the nuts.
3. Clean the pipe over the entire circumference where the clamp is to be installed. Be sure that there is no foreign debris (pebbles or dirt) on the clamp gasket or pipe. Lubricate the entire clamp gasket with a potable, NSF certified lube. ROBAR recommends SLIKSTYX.
4. A minimum of 4" of clamp is recommended beyond each side of the repair area. (i.e. If a 4" longitudinal crack is being repaired, a 12" long clamp is recommended). Also, a small hole can be drilled at each end of the crack to prevent it from spreading.
5. Slide the bolts under and around the pipe until the bolts point upwards.
6. Grasp the lifter bar on the bolts and pull it up and out until it snaps into position over the receiver lugs. Ensure that the gasket is not folded over. Tighten the nuts slightly by hand to prevent the lifter bar from lifting.
7. Tighten the nuts, using a torque wrench, evenly and incrementally. Start in the center, and move outward. Torque each nut to 80 ft. lbs.

ROBAR INDUSTRIES LTD.

Surrey, British Columbia
Phone: 1-800-663-6553

Boucherville, Quebec
Phone: 1-800-315-9525

Calhoun, Georgia
Phone: 1-706-624-4404

Website: www.robarindustries.com / E-mail: waterworks@robarindustries.com



5626 REPAIR CLAMP

INSTALLATION GUIDE



A standard feature of the 5626 (Style 2) ROBAR Repair Clamp is its ease of installation. All Robar Repair Clamps are pre-formed at the factory, allowing for easy installation.

1. Remove the clamp from its box. Ensure it has the required outside diameter for the desired application. Visually inspect the clamp to make certain there are no missing nuts, washers, or lifter bars. Unscrew all the nuts to the end of the bolts and separate the 2 sections. To avoid misplacing any components, do not completely remove the nuts.
2. Clean the pipe over the entire circumference where the clamp is to be installed. Be sure that there is no foreign debris (pebbles or dirt) on the clamp gasket or pipe. Lubricate the entire clamp gasket with a potable, NSF certified lube. ROBAR recommends SLIKSTYX.
3. A minimum of 4" of clamp is recommended beyond each side of the repair area. (i.e. If a 4" longitudinal crack is being repaired, a 12" long clamp is recommended). Also, a small hole can be drilled at each end of the crack to prevent it from spreading.
4. Drop the lug section of the clamp onto the pipe. Make sure the tapered gasket ends are not folded over.
5. Slide the bolt section of the clamp underneath the pipe. Gently grasp both lifter bars and pull up and outwards until they snap into place over the receiver lugs. The gaskets should remain flat along the pipe and free to move into position.
6. Tighten the nuts, using a torque wrench, evenly and incrementally. Start in the center, and move outward, criss-crossing between sections. Be sure to maintain an equal distance between the clamp sections. Torque each nut to 80 ft. lbs.

ROBAR INDUSTRIES LTD.

Surrey, British Columbia
Phone: 1-800-663-6553

Boucherville, Quebec
Phone: 1-800-315-9525

Calhoun, Georgia
Phone: 1-706-624-4404

Website: www.robarindustries.com / E-mail: waterworks@robarindustries.com



5636 REPAIR CLAMP

INSTALLATION GUIDE



A standard feature of the 5636 (Style 3) ROBAR Repair Clamp is its ease of installation. All Robar Repair Clamps are pre-formed at the factory, allowing for easy installation.

1. Remove the clamp from its box. Ensure it has the required outside diameter for the desired application. Visually inspect the clamp to make certain there are no missing nuts, washers, or lifter bars.
2. Assemble the clamp sections together, leaving one section open to wrap around the pipe. Be sure to leave a 1" - 1-1/2" gap between the clamp sections.
3. Clean the pipe over the entire circumference where the clamp is to be installed. Be sure that there is no foreign debris (pebbles or dirt) on the clamp gasket or pipe. Lubricate the entire clamp gasket with a potable, NSF certified lube. ROBAR recommends SLIKSTYX.
4. A minimum of 4" of clamp is recommended beyond each side of the repair area. (i.e. If a 4" longitudinal crack is being repaired, a 12" long clamp is recommended). Also, a small hole can be drilled at each end of the crack to prevent it from spreading.
5. Wrap the clamp around the pipe, making sure not to fold over the tapered gasket ends.
6. Grasp the lifter bar on the bolts and pull it up and out until it snaps into position over the receiver lugs. Tighten the nuts slightly by hand to prevent the lifter bar from lifting.
7. Tighten the nuts, using a torque wrench, evenly and incrementally. Start in the center, and move outward, criss-crossing between sections. Be sure to maintain an equal distance between the 3 clamp sections. Torque each nut to 80 ft. lbs.

ROBAR INDUSTRIES LTD.

Surrey, British Columbia
Phone: 1-800-663-6553

Boucherville, Quebec
Phone: 1-800-315-9525

Calhoun, Georgia
Phone: 1-706-624-4404

Website: www.robarindustries.com / E-mail: waterworks@robarindustries.com



5626/5636EZ REPAIR CLAMP

INSTALLATION GUIDE



A standard feature of the 5626 / 5636 (Style 2 & 3) ROBAR Repair Clamp is its ease of installation. All Robar Repair Clamps are pre-formed at the factory, allowing for easy installation.

1. Remove the clamp from its box. Ensure it has the required outside diameter for the desired application. Visually inspect the clamp to make certain there are no missing nuts, washers, or lifter bars.
2. Clean the pipe over the entire circumference where the clamp is to be installed. Be sure that there is no foreign debris (pebbles or dirt) on the clamp gasket or pipe. Lubricate the entire clamp gasket with a potable, NSF certified lube. ROBAR recommends SLIKSTYX.
3. A minimum of 4" of clamp is recommended beyond each side of the repair area. (i.e. If a 4" longitudinal crack is being repaired, a 12" long clamp is recommended). Also, a small hole can be drilled at each end of the crack to prevent it from spreading.
4. Slide the bolts on the open end of the clamp under and around the pipe until the bolts point upwards.
5. Grasp the lifter bar on the bolts and pull it out and up until it snaps into position over the receiver lugs. Tighten the nuts slightly by hand to prevent the lifter bar from lifting during rotation.
6. Rotate the repair clamp in the direction of the arrow. This will ensure that the gasket is properly seated and not folded over.
7. Tighten the nuts, using a torque wrench, evenly and incrementally. Start in the center, and move outward, criss-crossing between sections. Be sure to maintain an equal distance between the clamp sections. Torque each nut to 80 ft. lbs.

ROBAR INDUSTRIES LTD.

Surrey, British Columbia
Phone: 1-800-663-6553

Boucherville, Quebec
Phone: 1-800-315-9525

Calhoun, Georgia
Phone: 1-706-624-4404

Website: www.robarindustries.com / E-mail: waterworks@robarindustries.com



6400 / 6500

INSTALLATION GUIDE



All ROBAR Tapping Sleeves are leak tested at the factory prior to shipping.

1. Visually inspect the Tapping Sleeve to ensure it is of the required outside diameter and outlet size for the desired application. Make sure the Tapping Sleeve is complete and there are no missing nuts, bolts or washers.
2. Clean the pipe over the entire circumference where the sleeve is to be installed. Be sure that there is no foreign debris (pebbles or dirt) on the clamp gasket or pipe. Lubricate the sleeve gasket with a potable, NSF certified lube. ROBAR recommends SLIKSTYX.
3. Place the flange section of the sleeve on the pipe and slide it into position.
4. Slide the back section(s) over the back of the pipe and into position. Insert the bolts into corresponding bolt holes and tighten the nuts by hand. Be sure to maintain an equal gap between the tapping sleeve sections.
5. Tighten each nut, starting in the center, moving outward while alternating between the sleeve sections. Torque each nut to 80 ft. lbs.
6. Mount the tapping valve to the flange. An O-Ring gasket is supplied with the tapping sleeve, eliminating the need for a flange gasket. Be sure to support or block the valve.
7. Connect the tapping machine. Pressure test the tapping sleeve prior to cutting into the pipe. Testing can either be done through the tapping machine or through the 3/4" test plug. When testing through the test plug, before testing apply sufficient Teflon tape when resealing the 3/4" plug.
8. Proceed with the tapping operation. Prior to backfilling, be sure to double check the torque levels on each nut.

ROBAR INDUSTRIES LTD.

Surrey, British Columbia
Phone: 1-800-663-6553

Boucherville, Quebec
Phone: 1-800-315-9525

Calhoun, Georgia
Phone: 1-706-624-4404

Website: www.robarindustries.com / E-mail: waterworks@robarindustries.com



6606

INSTALLATION GUIDE



All ROBAR Tapping Sleeves are leak tested at the factory prior to shipping.

1. Visually inspect the tapping sleeve to ensure it is of the required outside diameter and outlet size for the desired application. Make sure the tapping sleeve is complete and there are no missing nuts, bolts or washers.
2. Separate the 2 sections of the tapping sleeves for sleeves 4" - 16" nominal OD. Remove the nuts, washers and lifter bars and be careful not to misplace them. Larger OD tapping sleeves are supplied with 3 sections. For a 3 section sleeve, loosely assemble the 2 back sections. Be sure to leave a 1" - 1-1/2" gap between the 2 sections.
3. Clean the pipe over the entire circumference where the sleeve is to be installed. Be sure that there is no foreign debris (pebbles or dirt) on the clamp gasket or pipe. Lubricate the entire sleeve gasket with a potable, NSF certified lube. ROBAR recommends SLIKSTYX.
4. Place the flange section of the sleeve on the pipe and slide it into position. Be sure that tapered gasket ends are not folded over.
5. Slide the back section(s) over the back of the pipe and into position, lining up the bolts with the receiver lugs. Verify that the gasket are lying flat on the pipe and are not folded over.
6. Install the lifter bars, followed by the stainless steel washers and nuts. Be sure to maintain equal gaps between the sleeve sections when tightening the bolts. Tighten each nut, starting in the center, moving outward while alternating between the sleeve sections. Torque each nut to 80 ft. lbs.
7. Mount the tapping valve to the flange. Be sure to support or block the valve.
8. Connect the tapping machine. Pressure test the tapping sleeve prior to cutting into the pipe. Testing can either be done through the tapping machine or through the 3/4" test plug. When testing through the test plug, before testing apply sufficient Teflon tape when resealing the 3/4" plug.
9. Proceed with the tapping operation. Prior to backfilling, be sure to double check the torque levels on each nut.

Tapping Sleeve rated for 150 PSI working pressure (contact Robar for higher pressure ratings).

ROBAR INDUSTRIES LTD.

Surrey, British Columbia
Phone: 1-800-663-6553

Boucherville, Quebec
Phone: 1-800-315-9525

Calhoun, Georgia
Phone: 1-706-624-4404

Website: www.robarindustries.com / E-mail: waterworks@robarindustries.com



6606BB

INSTALLATION GUIDE



All ROBAR Tapping Sleeves are leak tested at the factory prior to shipping.

1. Visually inspect the tapping sleeve to ensure it is of the required outside diameter and outlet size for the desired application. Make sure the tapping sleeve is complete and there are no missing nuts, bolts or washers.
2. Clean the pipe over the entire circumference where the sleeve is to be installed. Be sure that there is no foreign debris (pebbles or dirt) on the clamp gasket or pipe. Lubricate the sleeve gasket with a potable, NSF certified lube. ROBAR recommends SLIKSTYX.
3. Place the flange section of the sleeve on the pipe and slide it into position. Be sure that tapered gasket ends are not folded over.
4. Slide the back section(s) over the back of the pipe and into position. Insert the bolts into corresponding bolt holes and tighten the nuts by hand. Be sure to maintain an equal gap between the tapping sleeve sections.
5. Tighten each nut, starting in the center, moving outward while alternating between the sleeve sections. Torque each nut to 80 ft. lbs.
6. Mount the tapping valve to the flange. Be sure to support or block the valve.
7. Connect the tapping machine. Pressure test the tapping sleeve prior to cutting into the pipe. Testing can either be done through the tapping machine or through the 3/4" test plug. When testing through the test plug, before testing apply sufficient Teflon tape when resealing the 3/4" plug.
8. Proceed with the tapping operation. Prior to backfilling, be sure to double check the torque levels on each nut.

Tapping Sleeve rated for 150 PSI working pressure (contact Robar for higher pressure ratings).

ROBAR INDUSTRIES LTD.

Surrey, British Columbia
Phone: 1-800-663-6553

Boucherville, Quebec
Phone: 1-800-315-9525

Calhoun, Georgia
Phone: 1-706-624-4404

Website: www.robarindustries.com / E-mail: waterworks@robarindustries.com



6626

INSTALLATION GUIDE



All ROBAR Tapping Sleeves are leak tested at the factory prior to shipping.

1. Visually inspect the outlet sleeve to ensure it is of the required outside diameter and outlet size for the desired application. Make sure the tapping sleeve is complete and there are no missing nuts, bolts or washers.
2. Separate the 2 sections of the outlet sleeve for sleeves 4"-16" nominal OD. Remove the nuts, washers and lifter bars and be careful not to misplace them. Larger OD outlet sleeves are supplied with 3 sections. For a 3 section sleeve, loosely assemble the 2 back sections. Be sure to leave a 1" - 1-1/2" gap between the 2 sections.
3. Clean the pipe over the entire circumference where the sleeve is to be installed. Be sure that there is no foreign debris (pebbles or dirt) on the clamp gasket or pipe. Lubricate the sleeve gasket with a potable, NSF certified lube. ROBAR recommends SLIKSTYX.
4. Place the flange section of the sleeve on the pipe and slide it into position .
5. Slide the back section(s) over the back of the pipe and into position. Insert the bolts into corresponding bolt holes and tighten the nuts by hand. Be sure to maintain an equal gap between the outlet sleeve sections.
6. Tighten each nut, starting in the center, moving outward while alternating between the sleeve sections. Torque each nut to 80 ft. lbs. Prior to backfilling, be sure to double check the torque levels on each nut.

Tapping Sleeve rated for 150 PSI working pressure (contact Robar for higher pressure ratings).

ROBAR INDUSTRIES LTD.

Surrey, British Columbia
Phone: 1-800-663-6553

Boucherville, Quebec
Phone: 1-800-315-9525

Calhoun, Georgia
Phone: 1-706-624-4404

Website: www.robarindustries.com / E-mail: waterworks@robarindustries.com



6636AS

INSTALLATION GUIDE



1. Visually inspect the Abandon Sleeve to ensure it is of the required outside diameter for the desired application. Make sure the Abandon Sleeve is complete and there are no missing nuts, bolts or washers.
 2. Clean the pipe over the entire circumference where the sleeve is to be installed. Be sure that there is no foreign debris (pebbles or dirt) on the clamp gasket or pipe. Lubricate the sleeve gasket with a potable, NSF certified lube. ROBAR recommends SLIKSTYX.
 3. Once the main stop is closed, remove the copper tubing for the corporation stop if still attached. Place the encapsulating section of the sleeve over the corp stop and onto the pipe. Make sure the tapered gaskets are folded over.
 4. Slide the back section(s) over the back of the pipe and into position.
 - A. Bolt Bracket Closure: Insert the bolts into the corresponding bolt holes and tighten the nuts by hand.
 - B. Finger-Bolt Closure: Slide the back section and line up the bolts with the receiver lugs. Install the lifter bars, washers and nuts.
- Be sure to maintain equal gaps between the sleeve sections and verify that the gaskets are not folded over.
5. Tighten each nut, starting in the center, moving outward while alternating between the sleeve sections. Torque each nut to 80 ft. lbs.

ROBAR INDUSTRIES LTD.

Surrey, British Columbia
Phone: 1-800-663-6553

Boucherville, Quebec
Phone: 1-800-315-9525

Calhoun, Georgia
Phone: 1-706-624-4404

Website: www.robarindustries.com / E-mail: waterworks@robarindustries.com



6800 / 6900

INSTALLATION GUIDE



All ROBAR Tapping Sleeves are leak tested at the factory prior to shipping.

1. Visually inspect the sleeve to ensure it is of the required outside diameter and outlet size for the desired application. Make sure the sleeve is complete and there are no missing nuts, bolts or washers.
2. Clean the pipe over the entire circumference where the sleeve is to be installed. Be sure that there is no foreign debris (pebbles or dirt) on the clamp gasket or pipe. Lubricate the sleeve gasket with a potable, NSF certified lube. ROBAR recommends SLIKSTYX.
3. Place the flange section of the sleeve on the pipe and slide it into position.
4. Slide the back section(s) over the back of the pipe and into position. Insert the bolts into corresponding bolt holes and tighten the nuts by hand. Be sure to maintain an equal gap between the tapping sleeve sections.
5. Tighten each nut, starting in the center, moving outward while alternating between the sleeve sections. Torque each nut to 80 ft. lbs.
6. Mount the tapping valve to the flange. Be sure to support or block the valve.
7. Connect the tapping machine. Pressure test the tapping sleeve prior to cutting into the pipe. Testing can either be done through the tapping machine or through the 3/4" test plug. When testing through the test plug, before testing apply sufficient Teflon tape when resealing the 3/4" plug.
8. Proceed with the tapping operation. Prior to backfilling, be sure to double check the torque levels on each nut.

Tapping Sleeve rated for 150 PSI working pressure (contact Robar for higher pressure ratings).

ROBAR INDUSTRIES LTD.

Surrey, British Columbia
Phone: 1-800-663-6553

Boucherville, Quebec
Phone: 1-800-315-9525

Calhoun, Georgia
Phone: 1-706-624-4404

Website: www.robarindustries.com / E-mail: waterworks@robarindustries.com



7400 / 7500

INSTALLATION GUIDE



1. Visually inspect the Flange Coupling Adapter to ensure it is of the required outside diameter for the desired application. Make sure the coupling is complete and there are no missing nuts, bolts or washers.
2. Clean the pipe end to ensure that all dirt and irregularities have been removed.
3. Slide the end ring over the pipe end.
4. Lubricate the coupling gaskets and the pipe with potable, NSF certified lube. ROBAR recommends SLIKSTYX. Slide the appropriate gasket over the pipe. The tapered end must face the pipe ends.
5. Slide the center ring over the pipe. Position the flanged end of the center ring against the mating flange. An O-Ring gasket is supplied with the FCA, eliminating the need for a flat flange gasket. Keep the pipe gap to a minimum.
6. Slide the bolts into place and assemble the flanged joint. Slide the gasket and endplate into place against the center ring.

Note: Longer end of crossbolt gets inserted on coupling end plate side.

7. Torque each bolt alternating between bolts in a “star” pattern to the torque levels indicated below:

4” - 8”:	80 ft. lbs.
10” - 12”:	100 ft. lbs.

CAUTION



Couplings do not prevent pipe pullout.
Suitable restraint should be used when required.

ROBAR INDUSTRIES LTD.

Surrey, British Columbia
Phone: 1-800-663-6553

Boucherville, Quebec
Phone: 1-800-315-9525

Calhoun, Georgia
Phone: 1-706-624-4404

Website: www.robarindustries.com / E-mail: waterworks@robarindustries.com



9626

INSTALLATION GUIDE



1. Remove the insert and wedges from the box and verify that the insert diameter corresponds to the inside diameter of the HDPE pipe.
2. Gently compress the insert by hand and slide the insert into the pipe. Slide the insert until the pipe stops touch the face of the pipe.
3. Examine the gap size in the insert to determine what size wedge is necessary:

Wedge # 1: Gap size 2-1/2" or less.
Wedge # 2: Gap size between 2-1/2" and 3".
Wedge # 3: Gap size 3" or greater.
4. Slide the appropriate wedge into place. The insert will slide in between the 2 laminated sections of the wedge. Using a hammer, gently tap the wedge until it fits tightly into the insert.
5. When the wedge is in its final position, there should be no gap between the insert and the pipe wall. If there are any gaps, remove the insert and reinstall using a larger wedge.

ROBAR INDUSTRIES LTD.

Surrey, British Columbia
Phone: 1-800-663-6553

Boucherville, Quebec
Phone: 1-800-315-9525

Calhoun, Georgia
Phone: 1-706-624-4404

Website: www.robarindustries.com / E-mail: waterworks@robarindustries.com